

HC10-R - Pass through dishwasher

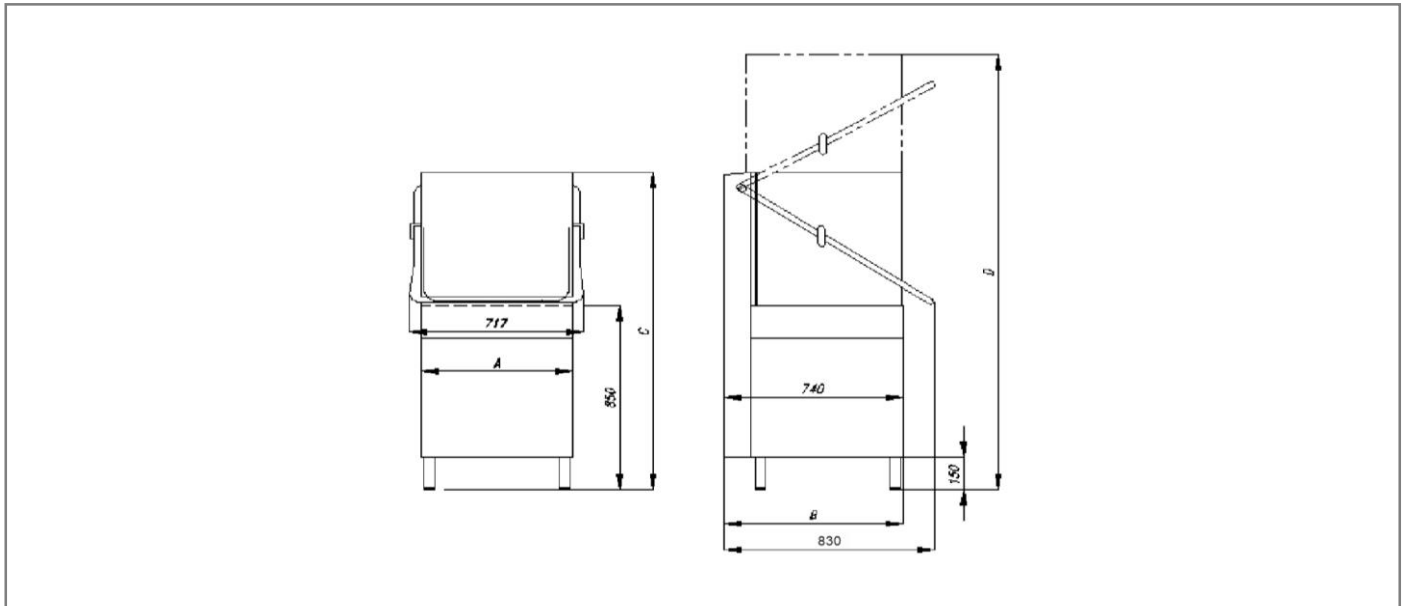

Technical features

External size	625x740x1520 (AxBxC) mm
Overall size	2020 (D) mm
Clearance	440 (E) mm
Rack size	500x500 mm
Tank size	42 l
Rinse water consumption	3,5 l
Wash pump	1,10 kW
Tank heater element	3,00 kW
Booster heater element	9,00 kW
Installed load	10,10 kW
Short cycle	65"
Output (racks/h)	55
Long cycle	240"
Electrical supply	230V/3/50Hz; 400V/3N/50Hz
Noise	67-69 dB(A)
Weight	118 kg
Control panel	TOUCH SCREEN
Wash arm	INOX
Rinse arm	INOX
Detergent injector	Standard
Rinse aid injector	Standard
Sanitizing injector	Optional
Air gap	Standard
Water softener	HC10-RA
Reverse osmosis	-
Heat recovery system	-
Drain pump	Standard