

Varimixer

KODIAK 30

VERY SIMPLE INTUITIVE OPERATION Set the time and speed. Press start and stop. It's that simple, and everything is controlled at an ergonomic working height from the angled control panel.

FRONT ATTACHMENT DRIVE

KODIAK is also available with an attachment drive for meat mincers and vegetable slicers.

PATENTED DETACHABLE SAFETY GUARD

The guard has an integrated filling tray, is made of transparent polycarbonate and is dishwasher-safe. It can be attached instantly without tools. The guard is held in place by magnets, which also serve as a safety cut-off.

WORLD'S MOST EFFECTIVE WHIP Unique design increases speed at the periphery and reduces the working time.

TWO MACHINES IN ONE The KODIAK 30-litre model can be supplemented with a smaller 15-litre bowl and associated tools, for production in reduced quantities. This increases the machine's versatility.

ERGONOMIC BOWL TROLLEY No heavy lifting is needed when the bowl is wheeled directly to and from the machine at worktop height. The bowl can be tipped, but is seated securely in a rubber ring during movement.

IP44 Varimixer KODIAK can be cleaned in line with the IP44 standard.

ERGONOMIC RAISING AND LOWERING The ergonomically designed handle lowers and raises the bowl and locks it in place in a single movement.

STAINLESS STEEL Made of easy-to-clean stainless steel with a strong frame and high, adjustable legs, to allow cleaning under the machine. The bowl, wire whip, beater, dough hook and scraper are also made of stainless steel and are dishwasher-safe.

RUNS ON 230 VOLTS KODIAK can be connected to a normal power outlet. A frequency converter and a three-phase motor make Varimixer KODIAK a very powerful mixer.

HEIGHT-ADJUSTABLE LEGS



VARIMIXER KODIAK 30 L OPTIONS - MODELS



Stainless steel, 30 L



Marine version, stainless steel, 30L

OPTIONS - ATTACHMENT DRIVE



Attachment drive for meat mincer and vegetable cutter



Meat mincer, 70 mm



Meat mincer, 82 mm

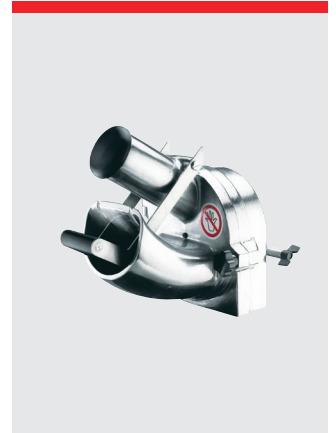

Vegetable cutter GR20

VARIMIXER KODIAK STANDARD TOOLS - A-EQUIPMENT 30 L



Hook, whip, beater and bowl 30 L in stainless steel.

VARIMIXER KODIAK TOOLS - B-EQUIPMENT 30/15 L



Hook, whip, beater and bowl 30/15 L in stainless steel.

ACCESSORIES - TOOLS



Automatic scraper in stainless steel. 30L and 30/15L.



Tool rack, 91 cm

VARIMIXER KODIAK30 STANDARD

Stainless steel
1 bowl 30 liter in stainless steel
1 beater in stainless steel
1 hook in stainless steel
1 whip in stainless steel
Removable magnetic safety guard guard plastic – CE-certified
Scraper holder
Digital timer and emergency stop
Voltage: 1 ph, 230V, 50-60 Hz. 1.200 W

VARIMIXER KODIAK30 STANDARD TECHNICAL DATA

Volume	30 l
Effect	1.200 W
Voltage*	230 V
Residual current devices (RCD):	
Industrial environment	HPFI type A-SI or PFI type B
Light industry/domestic	HPFI type A-SI
Net weight	190 kg
Shipping gross weight	210 kg
H x W x L (Shipping dimensions)	1590 x 700 x 800 mm
H x W x L (Product dimensions)	1365 x 630 x 770 mm
HS Code	84341010
Vol. m ³	0.89 m ³
Ldm	0.25
Variable speed	64 - 353 RPM
Phases	1 ph
IP code	IP44

*Other voltage power supply are available upon request in the range of 100 to 480 V. All standard and marine mixers are available in 50 and 60 Hz.

VARIMIXER KODIAK30 MARINE VERSION

Slotted free screws, fixed sealed power cable, supplied without plug. Gasket at machine lid. Built in transformer. Complies with USPHS.

Voltage: 2 ph, 400V, 50-60 Hz, ground, without neutral. 1.200 W
2 ph, 440V, 50-60 Hz, ground, without neutral. 1.200 W
2 ph, 480V, 50-60 Hz, ground, without neutral. 1.200 W

DIMENSIONS

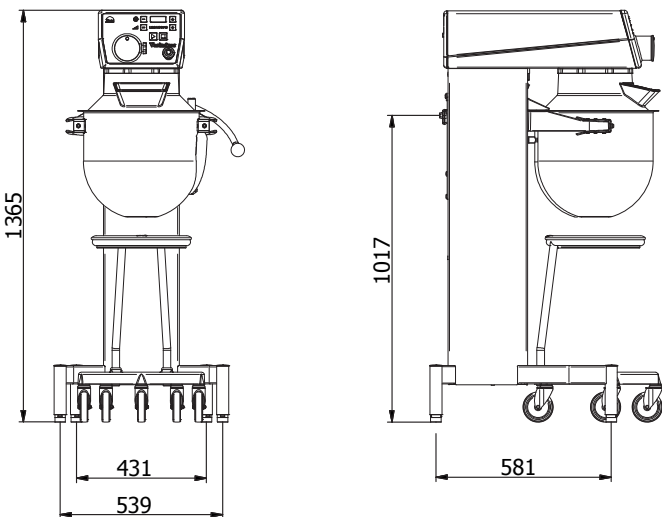

Varimixer

Varimixer A/S
Elementfabrikken 9
DK-2605 Brøndby
P: +45 4344 2288
E: info@varimixer.com
www.varimixer.com

CAPACITIES

Tools	Product		Special attention
Whip	Egg Whites	1.5 l	
	Whipped cream	5 l	
	Buttercream frosting	12 l	+ □
	Layer Cake Sponges	8 kg	
	Mayonnaise	12 l	+
Beater	Mashed potatoes	16 kg	+
	Cakes	15 kg	
	Icing, Fondant	9 kg	+ ○
	Herb Butter	9 kg	+ □
Hook	Meatball / Vegan meatball mix	18 kg	+
	Pasta, noodles (50%AR)	18 kg	○
	Dough, wheat (50%AR)	10 kg	○
	Dough, wheat (55%AR)	10 kg	○
	Dough, wheat (60%AR)	12 kg	○
	Dough, whole wheat (70%AR)	16.5 kg	
	Dough, rye bread	18 kg	+
	Dough, sourdough bread	16.5 kg	
	Dough, gluten free	14 kg	

The capacity chart shows the maximum capacity for the specific machine. The testing has been conducted with standard equipment. Therefore, the use of special tools, can result in a different outcome. Always start the machine at the lowest speed. Increase the speed subsequently, taking the product being mixed into account.

Symbols explainer - Recommended actions:

- + = Apply scraper, for the best and most efficient result
- = Always make sure the ingredients are room temperature/soft. If not, this can damage the tools.
- = Recommended to work on low speed.
- = Recommended not to go above medium speed.
- AR = Absorption Ratio (moisture in % of dry matter)

CERTIFICATIONS

