

Varimixer

KODIAK 20

Floor model

VERY SIMPLE INTUITIVE OPERATION Set the time and speed. Press start and stop. It's that simple, and everything is controlled at an ergonomic working height from the angled control panel.

IP44 Varimixer KODIAK can be cleaned in line with the IP44 standard.

FRONT ATTACHMENT DRIVE KODIAK is also available with an attachment drive for meat mincers and vegetable slicers.

PATENTED DETACHABLE SAFETY GUARD The guard has an integrated filling tray, is made of transparent polycarbonate and is dishwasher-safe. It can be attached instantly without tools. The guard is held in place by magnets, which also serve as a safety cut-off.

ERGONOMIC RAISING AND LOWERING The ergonomically designed handle lowers and raises the bowl and locks it in place in a single movement.

WORLD'S MOST EFFECTIVE TOOL Unique design increases speed at the periphery and reduces the working time.

STAINLESS STEEL Made of easy-to-clean stainless steel with a strong frame and high, adjustable legs, to allow cleaning under the machine. The bowl, wire whip, beater, dough hook and scraper are also made of stainless steel and are dishwasher-safe.

TWO MACHINES IN ONE The KODIAK 20-litre model can be supplemented with a smaller 12-litre bowl and associated tools, for production in reduced quantities. This increases the machine's versatility.

RUNS ON 230 VOLTS KODIAK can be connected to a normal power outlet. A frequency converter and a three-phase motor make Varimixer KODIAK a very powerful mixer.

ERGONOMIC BOWL TROLLEY No heavy lifting is needed when the bowl is wheeled directly to and from the machine at worktop height. The bowl can be tipped, but is seated securely in a rubber ring during movement.

HEIGHT-ADJUSTABLE LEGS



VARIMIXER KODIAK OPTIONS – MODELS



Stainless steel, 20 L floor



Marine version, Stainless steel, 20 L floor

OPTIONS – ATTACHMENT DRIVE



Attachment drive for meat mincer and vegetable cutter



Meat mincer, 70 mm



Meat mincer, 82 mm

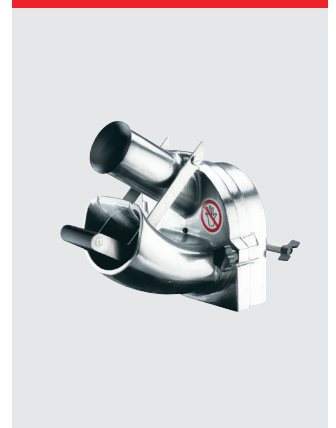

Vegetable cutter GR20

VARIMIXER KODIAK STANDARD TOOLS – A-EQUIPMENT 20 L



Hook, whip, beater and bowl 20 L in stainless steel.

VARIMIXER KODIAK TOOLS – B-EQUIPMENT 20/12 L



Hook, whip, beater and bowl 20/12 L in stainless steel.

ACCESSORIES - TOOLS

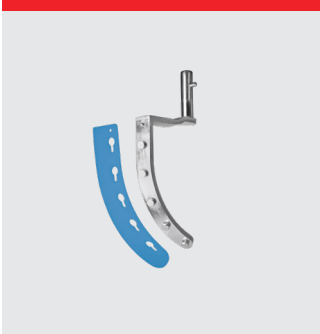

Automatic scraper in stainless steel. 20L and 20/12L.



Tool rack, 91 cm

VARIMIXER KODIAK20 STANDARD

| |
|--|
| Stainless steel |
| Removable magnetic safety guard guard plastic – CE-certified |
| Digital timer and emergency stop |
| Scraper holder |
| 1 bowl 20 liter in stainless steel |
| 1 beater in stainless steel |
| 1 hook in stainless steel |
| 1 whip in stainless steel |
| Voltage: 1 ph, 230V, 50-60 Hz. 700 W |

VARIMIXER KODIAK20 STANDARD TECHNICAL DATA

| | |
|---------------------------------|------------------------------|
| Volume | 20 l |
| Effect | 700 W |
| Voltage* | 230 V |
| Residual current devices (RCD): | |
| Industrial environment | HPFI type A-SI or PFI type B |
| Light industry/domestic | HPFI type A-SI |
| Net weight floor model | 165 kg |
| Shipping gross weight | 185 kg |
| H x W x L (Shipping dimensions) | 1590 x 700 x 800 mm |
| H x W x L (Product dimensions) | 1292 x 631 x 770 mm |
| HS Code | 84341010 |
| Vol. m ³ | 0.89 m ³ |
| Ldm | 0.25 |
| Variable speed | 64 - 353 RPM |
| Phases | 1 ph |
| IP code | IP44 |

*Other voltage power supply are available upon request in the range of 100 to 480 V. All standard and marine mixers are available in 50 and 60 Hz.

VARIMIXER KODIAK20 MARINE VERSION

Slotted free screws, fixed sealed power cable, supplied without plug. Gasket at machine lid. Built in transformer. Trolley with five wheels with brake locks. Complies with USPHS.

Voltage: 2 ph, 400V, 50-60 Hz, ground, without neutral. 700 W
2 ph, 440V, 50-60 Hz, ground, without neutral. 700 W
2 ph, 480V, 50-60 Hz, ground, without neutral. 700 W

DIMENSIONS

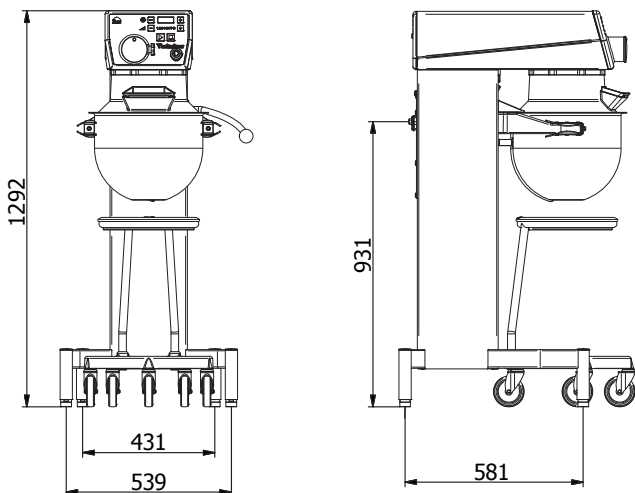

Varimixer

Varimixer A/S
Elementfabrikken 9
DK-2605 Brøndby
P: +45 4344 2288
E: info@varimixer.com
www.varimixer.com

CAPACITIES

| Tools | Product | Capacity | Special attention |
|--------|-------------------------------|----------|-------------------|
| Whip | Egg Whites | 1 l | |
| | Whipped cream | 4 l | |
| | Buttercream frosting | 8 l | + □ |
| | Layer Cake Sponges | 5.5 kg | |
| Beater | Mayonnaise | 8 l | + |
| | Mashed potatoes | 10 kg | + |
| | Cakes | 10 kg | |
| | Icing, Fondant | 6 kg | + ○ |
| Hook | Herb Butter | 6 kg | + □ |
| | Meatball / Vegan meatball mix | 12 kg | + |
| | Pasta, noodles (50%AR) | 12 kg | ○ |
| | Dough, wheat (50%AR) | 7 kg | ○ |
| | Dough, wheat (55%AR) | 7.5 kg | ○ |
| | Dough, wheat (60%AR) | 10 kg | ○ |
| | Dough, whole wheat (70%AR) | 11 kg | |
| | Dough, rye bread | 12 kg | + |
| | Dough, sourdough bread | 11 kg | |
| | Dough, gluten free | 9 kg | |

The capacity chart shows the maximum capacity for the specific machine. The testing has been conducted with standard equipment. Therefore, the use of special tools, can result in a different outcome. Always start the machine at the lowest speed. Increase the speed subsequently, taking the product being mixed into account.

Symbols explainer - Recommended actions:

- + = Apply scraper, for the best and most efficient result
- = Always make sure the ingredients are room temperature/soft. If not, this can damage the tools.
- = Recommended to work on low speed.
- = Recommended not to go above medium speed.
- AR = Absorption Ratio (moisture in % of dry matter)

CERTIFICATIONS

