



- Refrigerated hopper
- Product ready in less than 20 minutes*
- Direct drive cylinder mixer motor
- Brushless hopper mixer motor
- Modulated fan
- Multilanguage display
- Easy-to-remove filter

*room temperature 20° C

Slush	Sherbet	Sorbet	Drinks	Frozen Cocktails	Milkshakes	Frapuccinos	Cream	Juices	Soft Ice cream	Frozen yogurt
✓	✓	✓	✓	✓	✓	✓	✓			

Hopper capacity	18 l.
Cylinder capacity	7 l.
Voltage	220-240V/50-60 Hz
Net Weight	99 kg.
Max. power	2000 W
Amperage	less than 13A
Max. room temp.	40° C
Refrigerant gas	Propane (R-290)

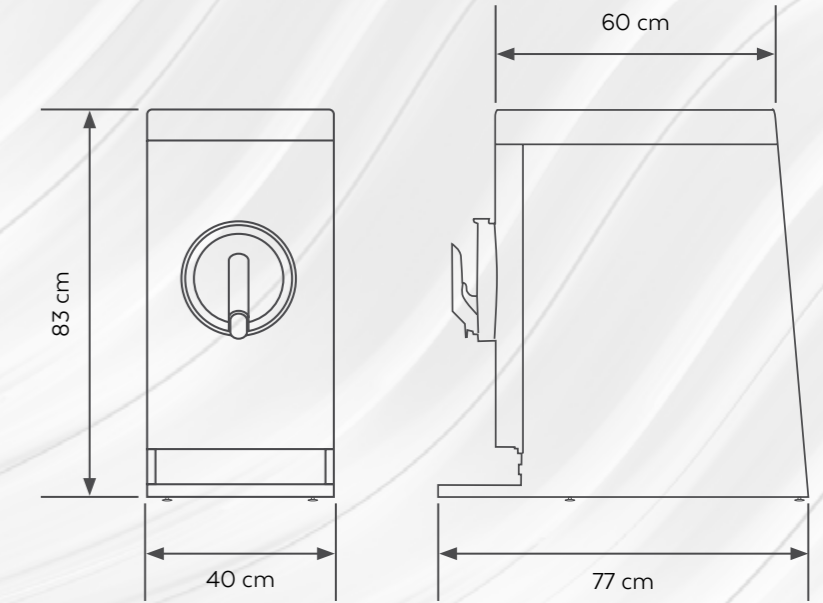

GBG 

 Sencotel

CARPIGIANI
H O R E C A