



Via Perotti, 5
25125 Brescia – Italy
Tel. +39 030 3581864
Fax +39 030 3581859
E-mail : cpspa@cpspa.it

FORMATRICE A FREDDO PER PIZZA – PIZZA'SPREADER (COLD Spinning System)

This machine reproduces the manual dexterity of the pizza-maker as closely as possible by imitating his unequalled delicateness. The original protected micro-rolling system, rigorously patented, results from a happy original intuition which was developed and achieved in order to knead the dough in the same way as the hands of an expert would. The exceptional performance of the machine is to achieve cold dough with the same kind of rim as would be obtained by a skilful pizza-maker, without any alteration. The machine is really easy and practical to use and the portions of Dough are always perfectly flattened.

C'est la machine qui reproduit le mieux le travail manuel du pizzaiolo, en imitant sa délicatesse inégalable. Le système original de micro-roulage protégé, rigoureusement breveté dans le monde entier, prend naissance d'une intuition bonne et originale qui a été développée et concrétisée pour obtenir le façonnage de la pâte semblable à celui des mains expérimentées. Le caractère exceptionnel de la machine consiste à laisser à la pâte étalée le bord exactement comme il le serait s'il avait été fait par les mains





Via Perotti, 5
25125 Brescia – Italy
Tel. +39 030 3581864
Fax +39 030 3581859
E-mail : cpspa@cpspa.it

Dimensions

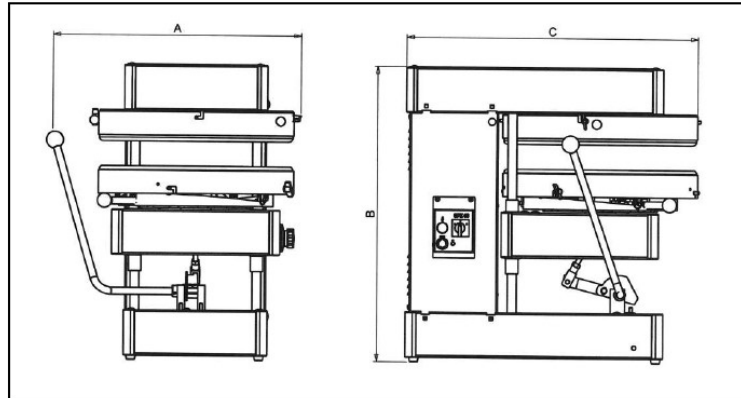

MODEL	A	B	C	Power [kW]	Φ Plate [mm]
SPZ 40	570mm (22")	770mm (31")	720mm (28")	0.55	400 (16")
SPZ 50	700mm (27")	840mm (33")	820mm (32")	0.75	500 (20")

Voltage:
SPZ 40-50: 230V/1/50Hz
(Optional: special voltages)

Transmission: belts.

Protections: emergency button.

Control panel: the START & STOP is given by the approach/separation of the carpets by the lift lever.

Shipping information

Model	Net weight	Gross weight	
		Pallet	Cage
SPZ 40	120kg (264lb)	130kg (286lb)	170kg (374lb)
SPZ 50	150kg (330lb)	160kg (352lb)	200kg (440lb)

Information on the packaging

MODEL	Box on pallet		Cage/Crate	
	Dimensions [mm]	Volume [m ³]	Dimensions [mm]	Volume [m ³]
SPZ 40	750x900x1100 (29"x35"x43")	0.74 (26.2 ft ³)	980x830x1160 (38"x32"x45")	0.94 (33.2 ft ³)
SPZ 50	750x900x1100 (29"x35"x43")	0.74 (26.2 ft ³)	980x830x1160 (38"x32"x45")	0.94 (33.2 ft ³)