

ORACBS (Black)

HIGH SPEED OVEN.

ORACRS (Red)

ALL IN ONE. COMBI WAVE / HIGH SPEED OVEN.

*TOTAL PLUG & PLAY
DESIGNED FOR USE ANYWHERE*

ORACGS (Steel)

STANDARD models



ALL IN ONE



High Speed Oven

Speed in its purest form so you don't keep your customers waiting.



Combi Wave

Maximum flexibility in the preparation stages.

AN ALL-AROUND PERFORMER FOR YOUR BUSINESS



High Speed Oven

An operating mode that simultaneously uses convection, microwave and impingement modes, with temperatures from 100°C to 300°C.



Fast Cooking System

Rely on Lainox's know-how by using the automatic, tried-and-tested recipes for high-speed cooking in High Speed Oven mode.



Combi Wave

In Combi Wave mode, Oracle can be used as a convection oven with temperatures from 30°C to 300°C, as a microwave oven with power up to 2000W or with a combination of the two cooking methods to achieve results that always exceed expectations.



Microwave Cooking System

Rely on Lainox's know-how by using the automatic, tried-and-tested recipes for cooking in Combi Wave mode.



Connected

Oracle connects free-of-charge to Lainox's Nabook plus portal via the standard-supply Wi-Fi and ethernet features giving you a 4.0 kitchen (find out more on nabookplus.cloud).

General data

Base dimensions (W x D)	mm [inch]	426 x 510 [16.8 x 20.1]	Weight - Net / Gross	kg [lbs]	63 / 75 [139 / 165.4]
External dimensions (W x D x H)	mm [inch]	467 x 609 x 630 [18.4 x 24 x 24.8]	Cooking chamber dimensions (W x D x H)	mm [inch]	310 x 320 x 180 [12.2 x 12.6 x 7]
Maximum external dimensions (W x D x H)	mm [inch]	467 x 657 x 630 [18.4 x 25.9 x 24.8]	Capacity	lt [ft³]	17.9 [0.64]
Dimensions with packing (W x D x H)	mm [inch]	600 x 800 x 800 [23.6 x 31.5 x 31.5]	Volume	m³ [ft³]	0.20 [7.06]



Power supply

Total electric power	kW	3	Power supply voltage	V	1N-AC 230 V
Impingement	kW	3	Frequency	Hz	50 Hz
Microwave	kW	1	Electric connection type		 (BS1363/A 2 mt.)
Consumption	A	13	Cable length	mt [ft]	2 [6.5]

Cooking modes

High Speed Oven		°C [°F]	100 - 300 [212 - 572]
Combi Wave	Convection	°C [°F]	30 - 300 [86 - 572]
	Microwave	W	1000

OPTIONAL ELECTRIC CONFIGURATION, WITHOUT EXTRA CHARGE - TO BE REQUESTED WHEN ORDERING OVEN

Models	Total electric power		Power Output		Power supply voltage	Electric connection type (Plug included)		Cable length (Included)	Option code
			Impingement	Microwave					
	kW	A	kW	kW		mt.			
ORACBS ORACRS ORACGS	3,6	16	3	1	1N-AC 230 V - 50Hz	IEC 309		2	OR3092
	3,6	18	3	1	1N-AC 208 V - 60Hz	Not included		2	OR1208
	3,6	16	3	1	1N-AC 240 V - 60Hz	Not included		2	OR1240
	3	13	3	1	1N-AC 230 V - 50Hz	BS1363/A		2	OR1363
	3,3	15	3	1	1N-AC 230 V - 50Hz	A53112		2	OR53112

COOKING METHODS

- Programmable mode: possibility of programming and storing a recipe with its cooking procedures in automatic sequence.

High Speed Oven

- FCS (Fast Cooking System) automatic cooking system for Italian and international recipes, including the history, ingredients, cooking accessories, method and automatic cooking program.
- Manual mode with instant start.

Combi Wave

- MCS (Microwave Cooking System) automatic cooking system for Italian and international recipes, including the history, ingredients, cooking accessories, procedure and automatic cooking program.
- Manual mode with three instant start cooking methods: convection, microwave or combined convection + microwave.

WI-FI/ETHERNET Nabook plus CONNECTIVITY

- Nabook plus. You can access Nabook plus, the virtual cooking assistant, thanks to access to the Cloud.
- Recipe creation including ingredients with procedure and photo.
- Direct access by Oracle to the recipe database with download option (patented).
- Synchronisation of multiple Oracle ovens connected to the same account (patented).
- HACCP Monitoring.
- Remote diagnosis through the Nabook plus portal by the LAINOX Service Center.
- Automatic software update notification system.
- Possibility to download recipes from the Nabook plus portal based on country.
- Automatic software updates on multiple devices simultaneously.

OPERATION

- 7" LCD colour screen, high definition, capacitive, with "Touch Screen" functions.
- Display that can be configured based on the needs of the user, bringing forward the programmes used most.
- Automatic cooking with "One Touch" start.
- Organisation of recipes in folders with preview, giving each folder its own name.
- Possibility of preheating the cooking chamber up to 300°C.
- Automatic resumption of cooking in case of a power failure.
- Rapid cooling of the cooking chamber with open door.
- User interface with a choice of 29 languages.
- There are numerous recipes available in Oracle and a growing number of alternative ones are available via access to the Nabook plus portal. Each recipe has been tested to guarantee best results.
- Oracle coach. Virtual assistant that provides advice on using Oracle and informs when maintenance is needed.

CONTROL MECHANISMS

Automatic fan speed for High Speed Oven mode.

Possibility of choosing the fan speed in Combi Wave mode.

USB connection to download HACCP data, update software and upload/download cooking recipes.

CONSTRUCTION

Made of stainless steel.

1-mm-thick AISI 304 stainless steel, diamond-patterned oven with wide radius fully rounded edges for optimal air flow and easy cleaning.

Perfectly smooth oven chamber.

Integrated catalyst filter for operation without hood.

Pull-down door with ergonomic handle.

The door slides under the oven cooking surface, allowing the food to be removed safely without the risk of burns.

Possibility of choosing the external colour.

SAFETY DEVICES

- Door open/closed electronic sensor.
- Self-diagnosis with smart error viewing.
- Max 65°C external temperature on the door panel.
- Compliant with the IEC60335-1, IEC60335-2-90 and EMC international standards.

CLEANING AND MAINTENANCE

- OWB, Oracle Washable Box, special removable and washable oven box.
- Easy external cleaning thanks to the perfectly smooth surfaces and IPX3 protection rating against water spray.

INSTALLATION & ENVIRONMENT

- 100% recyclable packaging.
 - Product recycling rate: 90%.
 - Certifications: Quality ISO 9001 / Safety ISO 45001 / Environment ISO 14001.
-

STANDARD EQUIPMENT

- COOKING PLATE
- ALUMINIUM PEEL (190 X 330)
- OWB - ORACLE WASHABLE BOX
- ADESIVE LINING FOR THE INSIDE OF THE DOOR (320 X 192)
- WI-FI CONNECTION
- ETHERNET CONNECTION
- USB CONNECTION
- POWER CABLE (2 MT.)
- PLUG (ONLY FOR 50 HZ)

MULTIPACK - TO BE REQUESTED WHEN ORDERING

- **MPACK:** MULTIPACK PACKAGING - 6 PCS MIXED IN A SINGLE PACKAGE (1200 X 800 X 2170 H - 415 KG - 2,08 M³)

OPTIONAL ELECTRIC CONFIGURATION, WITHOUT EXTRA CHARGE - TO BE REQUESTED WHEN ORDERING OVEN

- **OR3092** - OPTIONAL ELECTRIC CONFIGURATION. 1N-AC 230 V - 50 HZ. PLUG IEC 309
- **OR1208** - OPTIONAL ELECTRIC CONFIGURATION. 1N-AC 208 V - 60 HZ.
- **OR1240** - OPTIONAL ELECTRIC CONFIGURATION. 1N-AC 240 V - 60 HZ.
- **OR1363** - OPTIONAL ELECTRIC CONFIGURATION. 1N-AC 230 V - 50 HZ. 1N-AC 240 V - 50 HZ. PLUG BS1363/A
- **OR53112** - OPTIONAL ELECTRIC CONFIGURATION. 1N-AC 230 V - 50 HZ. 1N-AC 240 V - 50 HZ. PLUG A53112

EXTRA ACCESSORIES THAT CAN BE INSTALLED FOLLOWING PURCHASE

- **OCTL1:** TEFLON TRAY - SMOOTH - 2 PCS. (140 X 286 X 19 H)
- **OCTL2:** TEFLON TRAY - SMOOTH - 2 PCS. (286 X 286 X 19 H)
- **OCTF1:** TEFLON TRAY - PERFORATED - 2 PCS. (140 X 286 X 19 H)
- **OCTF2:** TEFLON TRAY - PERFORATED - 2 PCS. (286 X 286 X 19 H)
- **OPRGB:** GRILL PLATE - RIFLED. NON-STICK HEAT INPUT PLATE - ALUMINIUM ALLOY (286 X 300 X 11 H)
- **OPPC:** STONE PLATE (280 X 280 X 15 H)
- **OPC10B:** COOKING PLATE (300 X 295 X 11 H)
- **OPFA:** ALUMINIUM PEEL (190 X 330)
- **OPSAB:** UPPER SHELF REST (467 X 555 X 66 H)
- **OPCPB:** REAR COVER PANEL (560 X 465 X 100 H)
- **OWB:** ORACLE WASHABLE BOX. SPECIAL REMOVABLE, NON-STICK, WASHABLE TEFLON OVEN BOX. (305 X 322 X 180 H)
- **OKRI:** ADESIVE LINING FOR THE INSIDE OF THE DOOR (320 X 192)
- **OKP150:** SET OF FEET FOR OVEN (Ø 60 X 150 H)
- **OPL:** LEVELLING FEET (Ø 50 X M 10 X 46 H)
- **KFP002:** FOOT FASTENER KIT
- **OKSV:** STACKING KIT
- **OSR85:** STAINLESS STEEL FLOOR STAND WITH ADJUSTABLE FEET AND LOW SHELF (480 X 560 X 850 H)
- **OSR50:** STAINLESS STEEL FLOOR STAND WITH ADJUSTABLE FEET, FOR STACKING OF TWO ORACLE UNITS (480 X 560 X 550 H)
- **OSOCL** - LIQUID OVEN DETERGENT - CAPACITY 1 L. - PACK OF 6 PCS.
- **OSOPR** - LIQUID OVEN PROTECTOR - CAPACITY 1 L. - PACK OF 6 PCS.
- **OSTKB:** ACCESSORIES STARTER KIT. KIT CONSISTING OF 1 X OCTL2 + 1 X OCTF1 + 1 X OPRGB



Compact

Oracle, featuring a base just 51 cm deep and 42,6 cm wide, can be positioned in conventional spaces such as behind counters in bars, bistros, service stations and fast-food chains.

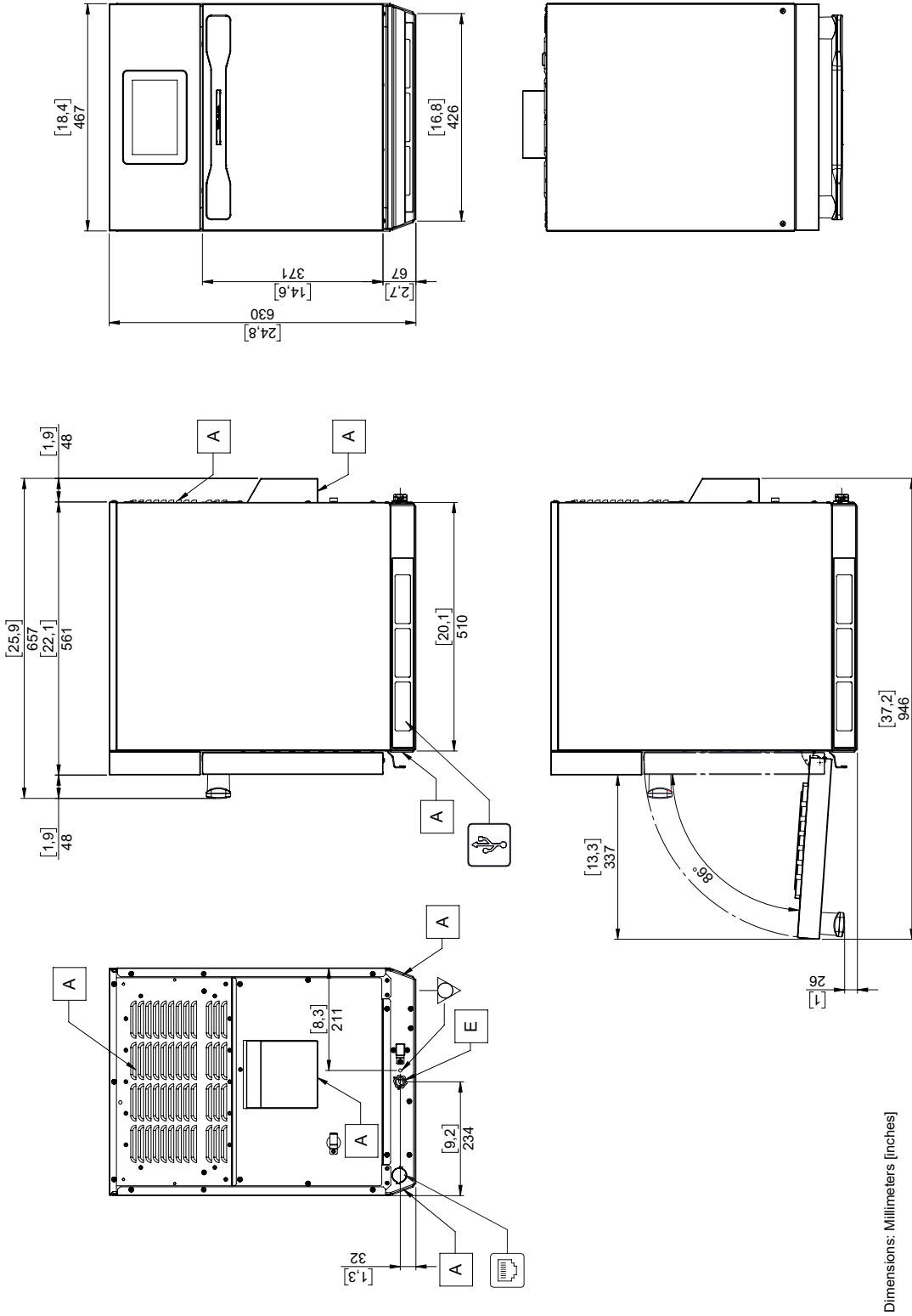

The data reported in this document is to be considered non-binding. The company reserves the right to make changes at any time, without prior notice.

CE IPX3

18.05.2022



LAINOX ALI Group Srl
 Via Schiaparelli 15
 Z.I. S. Giacomo di Veglia
 31029 Vittorio Veneto (TV) - Italy

Tel +39 0438 9110
 Fax +39 0438 912300
 lainox@lainox.com
 www.lainox.com

