

G1 GLASS FROSTER



G1 Glass Froster

Dimensions (mm)	External	Internal
Width	600	530
Depth	528	433
Height	853	695
Capacity		
Half-pint (275ml)	55*	
Temperature (°C)	-10 / -20°C	
Power Supply	230V/50Hz/1Ph	
Fuse (Amps)	13	
Refrigerant	R290	

KEY FEATURES

- Stainless steel exterior
- Polished stainless steel interior
- Barrel locked doors
- Coolsmart Controller for reduced energy consumption
- Solid heavy duty door
- 2 shelves

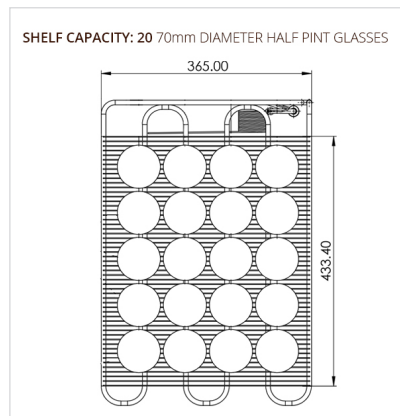

IMPORTANT NOTES:

Williams is committed to a policy of continual product development and innovation. As such, we reserve the right to change product specifications stated without prior notice.

* Capacity 55 when using shelves & base

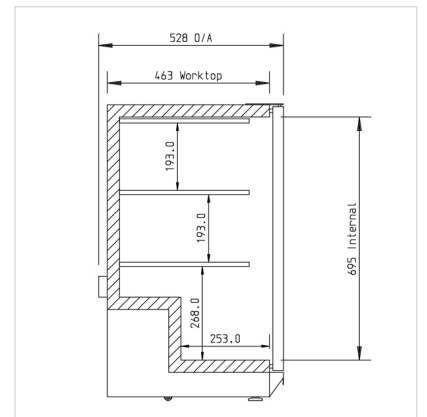
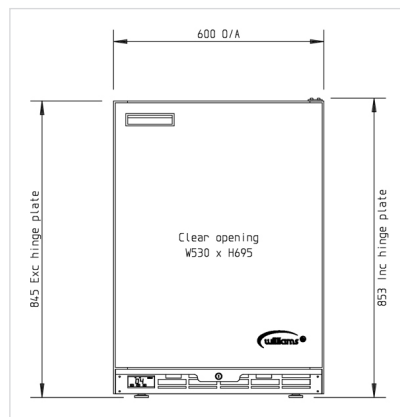

Williams Refrigeration
 Bryggen Road,
 North Lynn Industrial Estate
 King's Lynn, Norfolk. PE30 2HZ

T +44(0) 1553 817 000
 Spares: +44(0) 1553 817 017
 E info@williams-refrigeration.co.uk
 W www.williams-refrigeration.co.uk

