

Upright Cabinets

T-15G-HC~FGD01

 Slimline Upright Foodservice Refrigerator, 1 Full Glass Swing Door



Dimensions		Build		Technical	
External Width (mm)	632	Door Description	1 Full Glass Swing Door	Temperature Holding	0.5 : 3.3°C
External Depth (mm)	585	Door Opening	Right (standard) or Left.	Refrigerant	R290
External Height (mm)	1877	Exterior Construction	Stainless steel front, aluminium sides & rear	Voltage / Frequency / Phase	220-240V/50Hz/1
Exclusions	Depth does not include 42 mm for door handle or 13 mm for rear access panel.	Interior Construction	Clear coated aluminium, stainless steel base	Amps	1.4
Net Volume (Litres)	290	Air Intake Position	Front	Wattage	322
Gross Volume (Litres)	425	Ventilation Position	Rear	Temperature Class	M2
Display Area (m ²)	0.67	Clearance Required	26 mm rear, zero sides	Operating Statement	Tested at 25°C, 60% RH, per 'Refrigerators with a Direct Sales Function' for perishable food merchandising.
Supplied Shelves	5	Cord Length (Meters)	2.74	Testing Standard	EN 23953
Shelf Size (L x D mm)	524 x 445	Internal Lighting	LED	EEC	B
Internal Net Height (mm)	1300			EEL	13.2
Unpackaged Weight (kg)	105			kWh/24hr	2.19
Packaged Weight (kg)	116			kWh/Annum	802
Packaged Dimensions (W x D x H mm)	737 x 699 x 1918			Defrost Type	Auto
Supplied Supports	ø 51 mm castors (74 mm height)				



Specifications subject to change without notice. Technical data above related to energy use based on testing of 50Hz or Dual Frequency models Chart dimensions rounded up to the next whole millimeter (inches rounded up to the 1/8")

UK & Ireland [0800 783 2049](tel:08007832049)
 EMEA [+41 61 563 07 05](tel:+41615630705)
 Australia [+61 2 9619 9999](tel:+61296199999)

TFIUK@truemfg.com
TrueCHCustomerService@truemfg.com
TrueRefAus@truemfg.com



T-15G-HC~FGD01

🇬🇧 Slimline Upright Foodservice Refrigerator, 1 Full Glass Swing Door

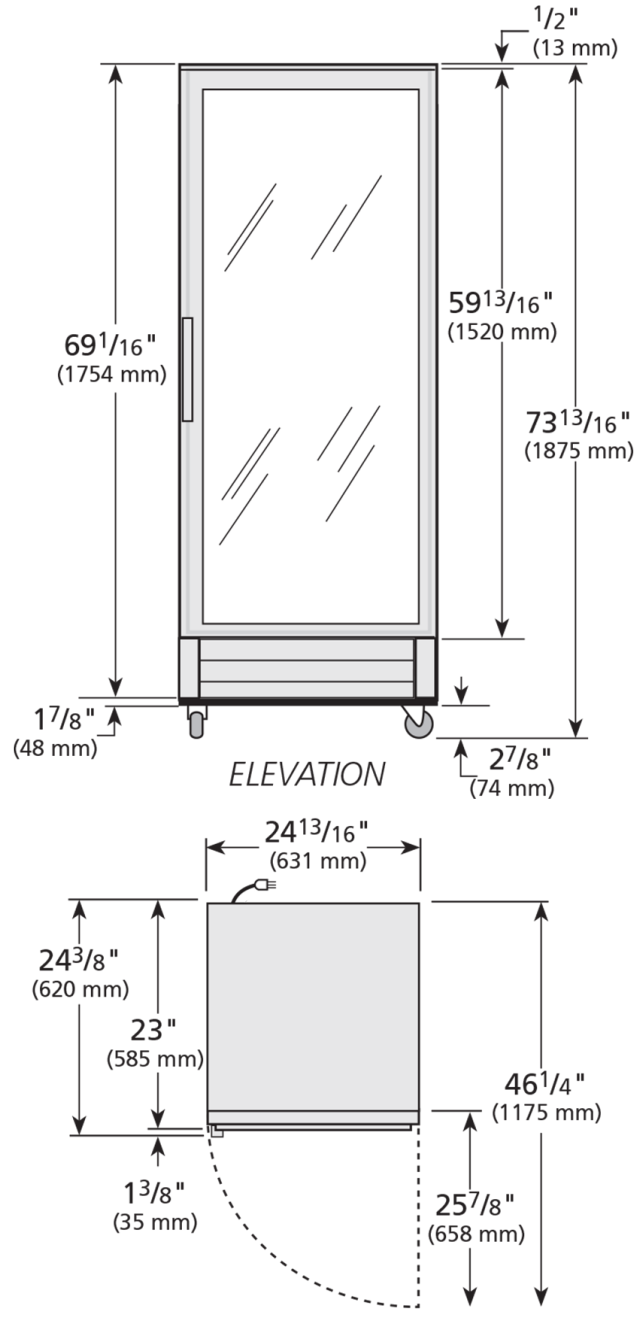

Specifications subject to change without notice.
Technical data above related to energy use based on testing of 50Hz or Dual Frequency models
Chart dimensions rounded up to the next whole millimeter (inches rounded up to the 1/8")

UK & Ireland [0800 783 2049](tel:08007832049)
EMEA [+41 61 563 07 05](tel:+41615630705)
Australia [+61 2 9619 9999](tel:+61296199999)

TFIUK@truemfg.com
TrueCHCustomerService@truemfg.com
TrueRefAus@truemfg.com

