



Cool cookline

Standard depth drawer + solid worktop



Blast Chill

For added functionality a BC option is available with Standard Drawers

Applications

- Bulk storage at the point of use in the cookline
- Designed for heavy cooking equipment, mounted on either a Heat Shield or Solid Worktop
- Ideal for meat and fish at the optimum storage temperature for each

Storage Capacity

Gastronorm (GN) Pans
4 x 1/1 GN
100 mm Deep
or equivalent (per Drawer)

Maximum Weight
40 kg of Food (per Drawer)

Volume
86 Litres (per Drawer)

Hydrocarbon R600a Refrigerant

Standard drawer

'B' Energy Rating
in Freezer Mode

'A' Energy Rating
in Fridge Mode
(Consumption 307
kWh/annum)

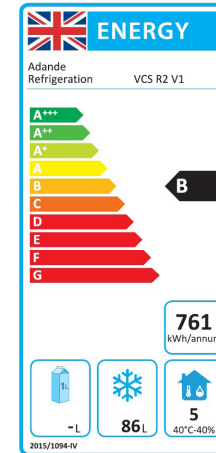

Climate Testing

Tested to **Climate Class 4**
(30°C & 55% relative humidity)
for temperature and energy
consumption and to **Climate
Class 5** (40°C & 40% relative
humidity) for temperature

Electrical

Mains Supply
230 Vac 50 Hz

Power Socket (included)
Correct 2 or 3 Pin Plug
fitted for each country

Mains Lead (included)
2 Metre Coiled Lead

+15°C ↔ -22°C





Options

CHEF BASE + SOLID WORKTOP (W)	High castor base (HC)		Standard castor base (C)		Small castor base (SC)		Rollers & feet base (R)		Small rollers & feet base (SR)		Fixed frame base (FF)		Mobile frame base (MF)	
Finished height	574 mm	VCS1/HCW	503 mm	VCS1/CW	482 mm	VCS1/SCW	458 mm	VCS1/RW	448 mm	VCS1/SRW	590-900 mm	VCS1/FFW	590-900 mm	VCS1/MFW
Load-bearing capacity	196 kg		273 kg		498 kg		299 kg		300 kg		185 kg		305 kg	

For full options please see our [Drawer Customising and Accessories](#) pages

Plan View

Chef base (VCS1)
With open drawer

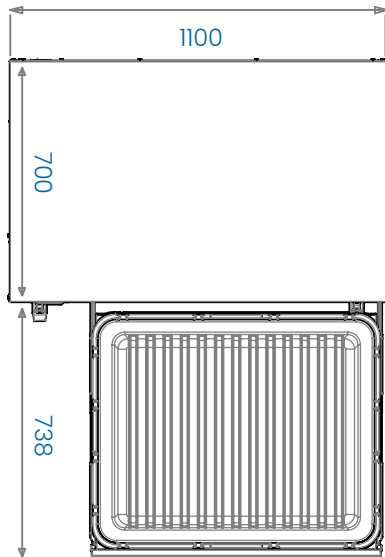

Elevation

Chef base - cool cookline (VCS1)
High castors (HC)
Solid worktop (W)
VCS1/HCW

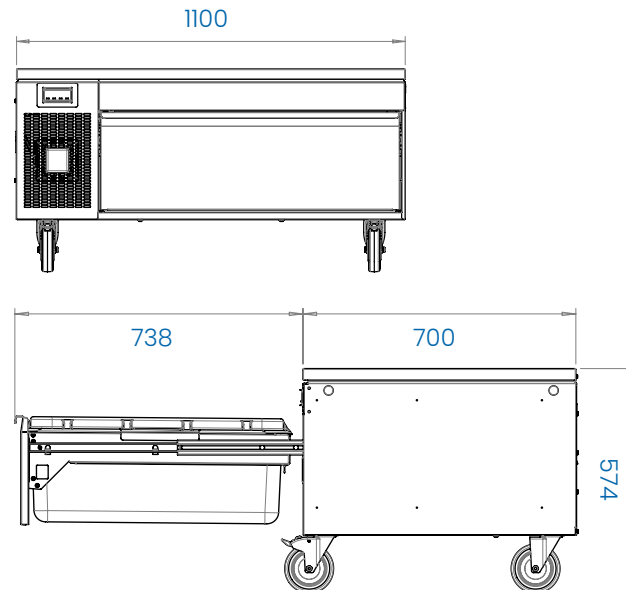

Tops



Drawer Module



Base

