



Authorized Distributor:
FOODSERVICE EQUIPMENT MARKETING
 10 CARRON PLACE-KELVIN IND.ESTATE G75 0YL GLASGOW()
 TEL./FAX. 0044-1355 244111 / 0044-1355 241471
 E-mail:saganm@fem.co.uk



Sirman Vacuum Packaging Machines , model Vertigo 30 :

Vertical compact vacuum packaging machine ideal for liquids, granulates and powders best for bars or as a second machine.

- Max bag size 300x350 mm which can easily hold 3 Lt
- EASY TOUCH controls
- Lid without pistons
- Practical niches on the profile to move the unit
- Extraordinary patented solution for internal cleaning:
- Transparent sides of the tank offer perfect visibility inside the tank
- Side panels can be easily and completely disassembled without tools for easy and thorough cleaning inside the tank



Data sheet

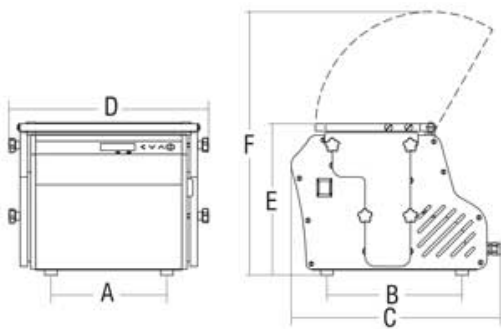

Technical data

Model	W8 30 Vertigo
Power	Kw 0.15
Power source	1ph
Vacuum pump	mc/h 4
Sealing bar	mm 310
Cavity dimensions	mm 326x60x250
A	mm 230
B	mm 268
C	mm 416
D	mm 396
E	mm 300
F	mm 521
Net weight	Kg 22
Shipping	mm 515x435x385
Net weight	Kg 24
HS-CODE	84224000