



## Convection Ovens

# FE4D Countertop Convection Oven

### Key features

- Convection oven with digital controls
  - Simple and intuitive to use
- 10 program storage
  - Consistent results regardless of who's cooking
- Audible alarm sounds when cooking program finished
  - Ensures food not left in oven too long and overcooks
- Water injection function allows a gentle burst of steam
  - Added flexibility and enhanced results
- Precise temperature control for perfect results
  - Thermostatically controlled convection oven
  - Bi-directional fan ensures even heat distribution
- Easy to monitor cooking progress in oven
  - Glass panelled door and internal LED light
- Double glazed oven door panel with removable internal pane
  - Greater heat retention and easy to clean
- Compatible with other standard kitchen equipment
  - Accommodates 4 x 1/1 GN sized trays & shelves
- Wide oven temperature range of 50 - 260°C
  - Ideal to prepare a wide variety of food
- Full height solid tube cool-touch door handle
  - Simple & easy to operate, nothing to go wrong
- Adds performance & capacity to any kitchen
  - Supplied with 13A plug & 1.8m cable so easy to install and can be located anywhere
  - Can be stacked for double the capacity
- Oven has 4 shelf positions with 4 shelves supplied
  - 80mm spacing between shelves
- Microswitch in door switches oven off if door open
  - Prevents unnecessary energy wastage

- Bevelled corners and removable oven racks
  - No dirt traps make the oven simple to clean

### Accessories

- Oven shelf
- Leg stand for single oven
- Low level stand with stacking kit
- Adjustable castors (for stand)

### Similar Models

- FE4M 1/1 GN convection oven - manual controls
- FE3D 2/3 GN convection oven - digital controls
- FE2M 2/3 GN convection oven - manual controls



# Convection Ovens

# FE4D

## Countertop Convection Oven

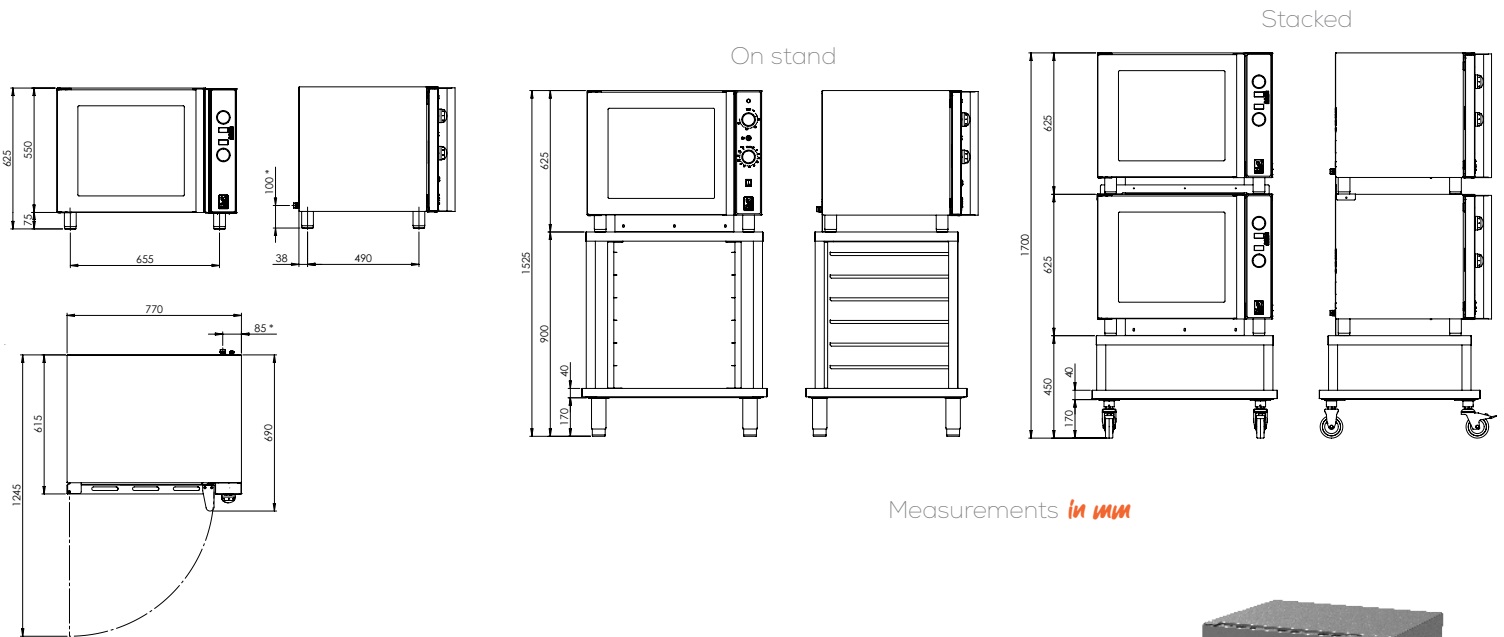

### Specification details

Total rating (kW)	2.65
Electrical supply voltage	230V N~
Electrical current split (A)	L1: 12
Oven dimensions (w x d x h - mm)	545 x 370 x 405
Oven shelf (w x d - mm)	545 x 370
Gastronorm compatibility	1/1
Weight (kg)	55
Packed weight (kg)	63
Packed dimensions (w x d x h - mm)	850 x 750 x 800
GTIN number	5056466907402



On fixed stand

### Installation notes

Adequate ventilation must be provided to supply sufficient fresh air and to allow easy removal of any such products that may present a risk to health. Please consult current legislation for details that relate to specific locations.

Install unit on a level, fireproof surface in a well-lit position. If floor is made of a combustible material, local fire requirements must be checked to ensure compliance.

A clearance of 150mm should be observed between appliance and any combustible wall.



FE4D stacked on FE4M



Falcon Foodservice Equipment, Wallace View, Hillfoots Road, Stirling FK9 5PY Scotland  
 t: +44 (0) 1786 455 200 e: info@falconfoodservice.com www.falconfoodservice.com