

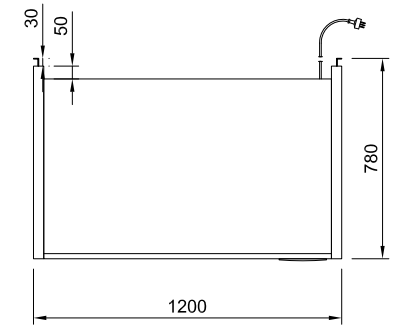

- Stainless steel construction
- Four adjustable shelves
- Ticket strips on shelves
- Shelf mounted air curtains
- Under shelf and canopy LED lights
- Pull down night blind
- Forced air circulation
- Integral condenser
- Removable front grill panel
- Roll in on castors
- Climate class M1
- Hinged front doors - **optional**

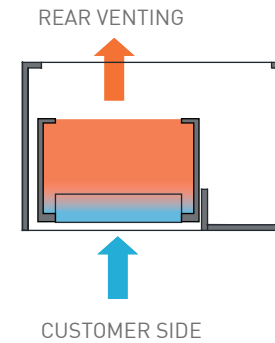

Drainage System Options

- Plastic bottle - manual empty
- Pump to waste
- Electronic evaporator pan



Shown with optional frameless hinged double glazed front doors
sold as accessory kit

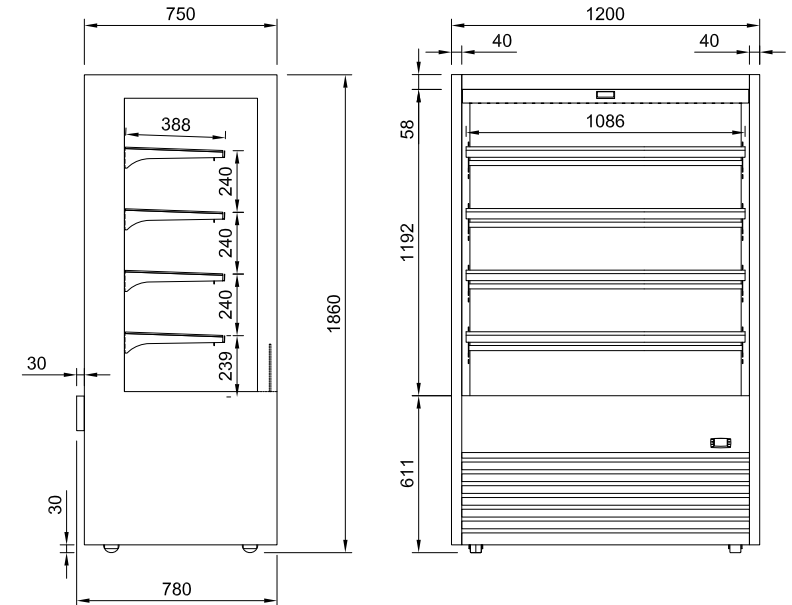

Prior to installation see, installation guidelines, ventilation requirements and drainage options documents

CABINET DIMENSIONS & SPECIFICATIONS

MODEL	CABINET				SHELVING	OPERATING TEMP	SHELF	BASE TRAY	DISPLAY	REFRIGERANT	FREQUENCY	OPERATING CURRENT	ENERGY CONSUMPTION	CONNECTION		VOLTAGE	PACKED FOR SHIPPING			
	LENGTH [MM]	DEPTH [MM]	HEIGHT [MM]	WEIGHT [KG]										DEG C	W X D		W X D	M ²	TEMP CLASS M1	Hz
DTGOR12	1200	780	1860	282	4 + BASE	-1 +5	1086 X 386	1120 x 453	2.18	R290	50/60 HZ	0.94 / 4.5	17.28	3 PIN PLUG	3 PIN PLUG	220-240V	1300	830	2030	292

Maximum shelf load weight 15kg spread evenly