

# BTGHT12 TOWER SERIES HEATED

COSSIGA

BTGHT12



## PRODUCT FEATURES

- Deck forced heating
- Single glazed
- Sliding rear doors
- Solid front or sliding front doors
- Four adjustable shelves - flat or angled
- Ticket strips on shelves and base
- Under shelf and canopy LED lights

Maximum shelf load weight 15kg spread evenly

BTGHT12-SD

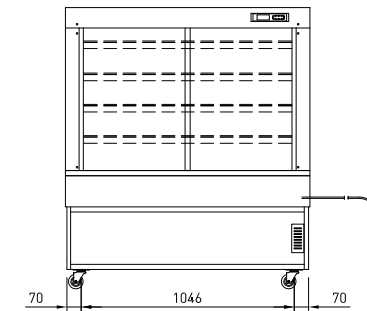
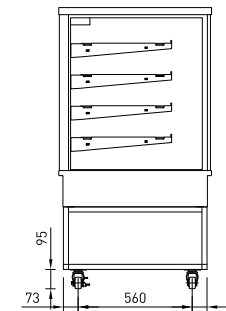
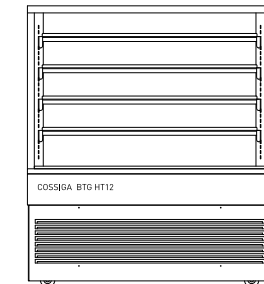
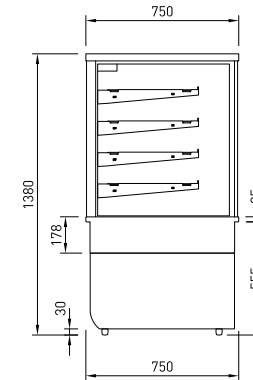
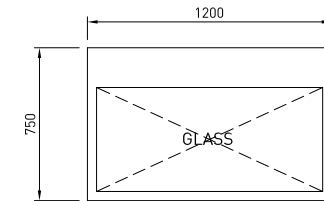

REAR VIEW

## CABINET DIMENSIONS & SPECIFICATIONS

Prior to installation see, installation guidelines, ventilation requirements and drainage options documents

MODEL	CABINET				SHELVING	OPERATING TEMP	SHELF	BASE TRAY	TOTAL FOOD	DISPLAY M <sup>2</sup>	INTERNAL VOLUME M <sup>3</sup>	FREQUENCY	POWER		CONNECTION ELECTRICAL POWER CORD 2200MM		VOLTAGE	PACKED FOR SHIPPING			
	LENGTH [MM]	DEPTH [MM]	HEIGHT [MM]	WEIGHT [KG]									DEG C	W X D	W X D	100MM UNITS		KW 230V	AMP	NZ/AUS 3 PIN	UK 13 AMP
BTGHT12 BTGHT12-SD	1200	750	1380	182	4 + BASE	75-85	1090 X 445	1140 x 510	255	2.52	0.60	50/60 HZ	2.20	9.6	15 AMP	3 PIN PLUG	220-240V	1300	830	1550	185