



Authorized Distributor:
FOODSERVICE EQUIPMENT MARKETING
 10 CARRON PLACE-KELVIN IND.ESTATE G75 0YL GLASGOW()
 TEL./FAX. 0044-1355 244111 / 0044-1355 241471
 E-mail:saganm@fem.co.uk

Sirman Vacuum Packaging Machines , model Vacuex :



- The ideal machine for container vacuum, very compact and user friendly.
- Easy to carry thanks to the upper handle.
- Bush suction pump as standard.
- Easy vacuum time setting.
- Counter and counter use pump.
- Oil preheat and cleaning cycle
- Oil and filter change message.
- Hose filter to avoid suction of solid parts.
- Hose filter cartridge easily removable.



1/3 GN - optional



1/2 GN - optional



1/1 GN - optional

Data sheet

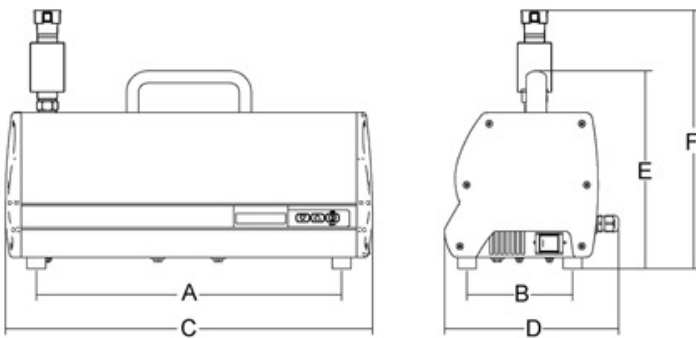

Technical data

Model	Vacuex 4	Vacuex 8
Power	Kw 0,1	kw 0,35
Power source	1ph	1ph
Vacuum pump	mc/h 4	mc/h 8
A	mm 406	mm 406
B	mm 140	mm 140
C	mm 488	mm 488
D	mm 232	mm 232
E	mm 262	mm 262
F	mm 343	mm 343
Net weight	kg 11	kg 16
Shipping	mm 550x300x300	mm 550x300x300
Gross weight	kg 13	kg 18
HS-CODE	84224000	