



F900

G934FX Single Pan Gas Fryer with Filtration

Key features

- High efficiency burner system
 - Quick heat up, reduced waiting time
- Oil capacity is just 18 litres
 - Efficient to heat and economical to fill up
- Automatic integrated 2-stage filtration
 - Increases oil longevity and quality
- Manual controls
 - Simple and ease to use
- Integrated fat melt cycle
 - Ability to use different cooking mediums
- IPX5 rated
 - Easy and problem-free cleaning
- Supplied with fish grid, lid and oil bucket
 - Everything you need to operate the fryer
- Stainless steel panels with Scotch Brite finish
 - Looks great, ideal for front-of-house kitchens
- Dynamic Link System compatible
 - Integrated linking system allows quick and easy installation to create a seamless, continuous cookline

Accessories

- Front hob rail
- Kick strip
- Rear blanking plate
- Side hob extension
- Factory fitted, adjustable castors

Similar Models

- G9341 single pan gas fryer
- E9341 single pan electric fryer
- E9341F single pan electric fryer with filtration



FRYER ANGEL

The unique *Falcon Fryer Angel* safety system prevents fryer fires, making it a must-have for any commercial kitchen.

The most common causes of fryer fire occur when oil levels are too low during cooking or when the appliance is switched on without the operator checking to see if there is enough oil in the pan. The *Falcon Fryer Angel* eradicates this by simply cutting power to the unit if the oil level is not at a sufficiently high level.

The Falcon Fryer Angel - making your kitchen safer!

Patent applied for, Patent Application No. 2002725.6 (UK), PCT/GB2020/050462 (International)

Single Pan Gas Fryer with Filtration

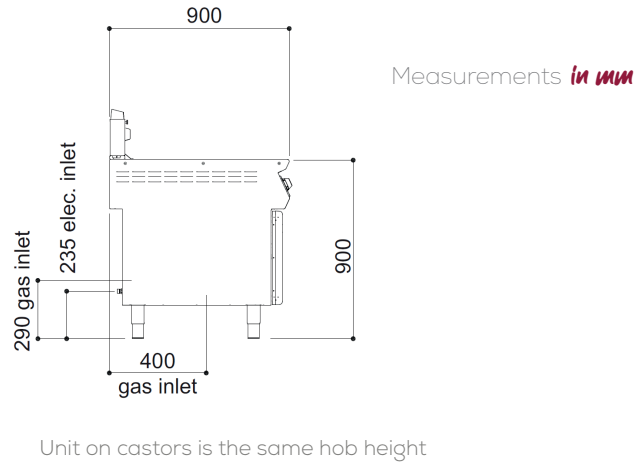
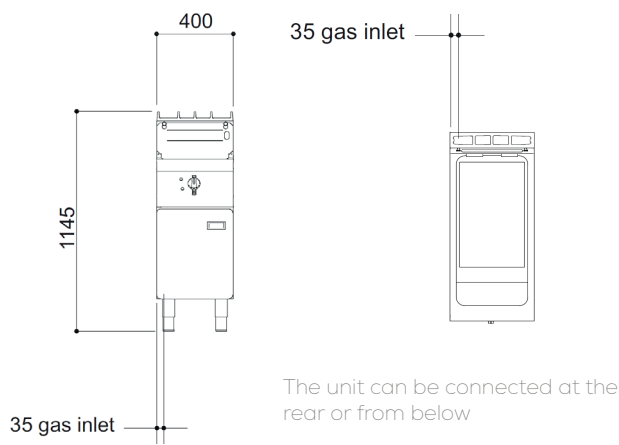

Specification details

	Natural Gas	Propane Gas	Butane Gas
Total rating (kW - Nett)	23	22	22
Total rating (btu/hr - gross)	86,348	82,594	82,594
Inlet size	3/4" BSP	3/4" BSP	3/4" BSP
Flow rate - natural (m ³ /hr)	2.26 m ³ /hr	1.60 kg/h	1.57 kg/h
Inlet pressure (mbar)	20	37	29
Operating pressure (mbar)	14	37	29
Burner rating * (kW)	23	22	22
Burner rating * (btu/hr)	86,348	82,594	82,594
Electrical supply	230V~		
Oil capacity (litres)	18		
Chip Output (kg/hr)	32		
Weight (kg)	94		
Packed weight (kg)	95		
Packed dimensions (w x d x h - mm)	490 x 1000 x 1015		
GTIN numbers			
Nat Gas (feet)	Nat Gas (castors)	LPG (feet)	LPG (castors)
5056466907112	5056466907129	5056466907136	5056466907143

Short Form specification

Unit to be Falcon F900 Series high performance gas single pan, twin basket fryer with in-built filtration. Unit to be supplied upon adjustable feet with a working oil capacity of 18 litres. Sensor technology should be inbuilt to monitor oil levels and cut power to unit if oil falls below minimum level.

The pan will be of open well design with burner situated below – allowing easy cleaning of the pan. Unit to be supplied with two baskets with coated handles that can be positioned at pan rear for oil drain off and storage. Oil to be drained from pan via large 1" drain valve into oil bucket which is to be self-contained inside the unit base. The oil temperature will be thermostatically controlled via precise controls from 130-190°C. The unit will have safety thermostat fitted as standard to prevent unit from overheating.

The hob will be constructed from 2mm 304 grade stainless steel. Hobs will be laser cut with right-angled edges to allow joining of units with no gaps between hobs. Exterior panels are Scotch Brite finish stainless steel. Control knobs to be marked showing gas positions and to have a bezel behind each knob to prevent water ingress. Unit will be for use with natural, propane or butane gas and be supplied with conversion kit.

Installation note

Please consult local legislation with regard to installation of cooking equipment.



Falcon Foodservice Equipment, Wallace View, Hillfoots Road, Stirling FK9 5PY Scotland
 t: +44 (0) 1786 455 200 e: info@falconfoodservice.com www.falconfoodservice.com