



Project:
Item Number:
Quantity:

INTERNATIONAL DUAL CONVEYOR TOASTERS - UP TO 1,100 SLICES PER HOUR COMBINED* (JT4)



DESCRIPTION

Vollrath's Dual Conveyor Toasters have two independently-controlled toasting chambers. These toasters provide the flexibility of two toasters in the footprint of one. They are ideal for mid-size restaurants that need to toast different bread products at the same time. Not intended for high-volume toasting operations.

WARRANTY

- Warrantied parts: The warranty period is 2 year parts, 1 year labor.
- Heater tubes: The warranty period is 1 year parts and labor. Heater tube glass damage is not covered by this warranty.
- For full warranty details, please refer to www.Vollrath.com.

AGENCY LISTINGS



** Slices per hour is based on maximum conveyor speed. Conveyor speed determines toasting time and affects color and texture of the toast. Results may vary based upon type of bread, color and texture preference.*

Due to continued product improvement, please consult www.vollrath.com for current product specifications.

ITEMS

Item No.	Model	Description
CT4-230DUAL	JT4	Dual Conveyor Toaster*, High Clearance

FEATURES

- Stainless steel and aluminized steel construction.
- Independent variable speed control for each chamber.
- Independent top and bottom heat control for each chamber.
- 14½" (36.8 cm) 3-slice wide conveyors are larger than industry standard for better toasting results.
- Top chamber product entry opening is adjustable from 1½" - 3" (3.8 - 7.6 cm).
- Bottom chamber product entry opening is adjustable up to 1½" (3.8 cm).
- Forced convection toasting promotes uniform results and energy efficiency.
- Energy efficient, fast reacting, quartz heaters.
- High-temperature bearings ensure smooth operation and do not require lubrication.
- High-quality, insulated wires help prevent against dry rotting and cracking.
- High-temperature thermoplastic terminal blocks with stainless steel clamping provides superior connections; designed for ease of serviceability.
- Maintenance-free drive system; stainless steel drive chain does not require lubrication.
- Independent standby mode for each chamber saves up to 75 percent energy during slow periods.
- Fan control switch senses temperature of unit and keeps fan running until unit is completely cool.
- Adjustable legs.
- 4½ ft. (1.4 m) cord with plug.
- Made in the USA.

CLEARANCE AND ENVIRONMENT REQUIREMENTS

- Do not place on surfaces or near walls, partitions or kitchen furniture unless they are made of non-combustible material or clad with non-combustible heat-insulating material. Toasters must not be used near or below curtains and other combustible materials.
- Maximum ambient temperature: 104° F (40 ° C).

Approvals	Date

The Vollrath Company, L.L.C. Headquarters
 1236 North 18th Street
 Sheboygan, Wisconsin
 53081-3201 USA
 Main Tel: 800-624-2051 or 920-457-4851
 Main Fax: 800-752-5620 or 920-459-6573
 Canada Customer Service: 800-695-8560
 Tech Services: techservices@vollrathco.com
www.vollrath.com

Pujadas
 Ctra. de Castanyet,
 132 P.O. Box 121
 17430 Santa Coloma de Farners
 (Girona) – Spain
 Tel. +34-972-84-32-01
info@pujadas.es

Vollrath of China
 Vollrath Shanghai Trading Limited
 Room 201, Building A
 Xin Yi Plaza
 1618 Yi Shan Road
 Shanghai, 201103
 China, P.R.C.
 Tel: +86-21-5058-9580

Vollrath de Mexico S. de R.L. de C.V.
 Periferico Sur No. 7980 Edificio 4-E
 Col. Santa Maria Tequepexpan
 45600 Tlaquepaque, Jalisco | Mexico
 Tel: (52) 333-133-6767
 Tel: (52) 333-133-6769
 Fax: (52) 333-133-6768

INTERNATIONAL DUAL CONVEYOR TOASTERS - UP TO 1,100 SLICES PER HOUR COMBINED* (JT4)

DIMENSIONS (Shown in inches (cm))

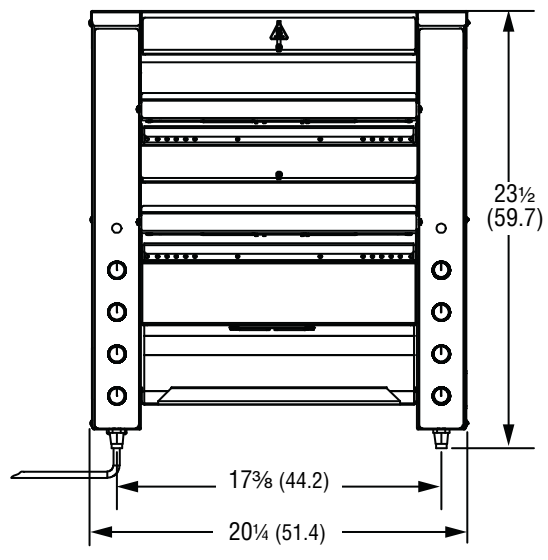

Front View

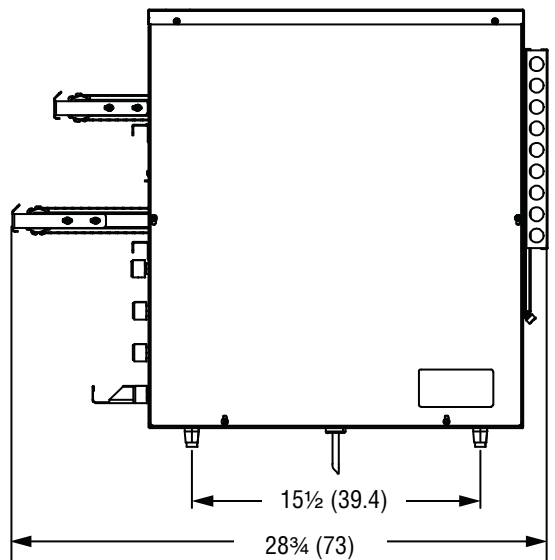

Side View

SPECIFICATIONS

Item No.	Model	Slices Per Hour Combined (Up To)*	Conveyor Width In (CM)	Product Clearance In (CM)		Voltage	Maximum Watts	Amps	Hz	Weight LB (KG)	Plug
				Bottom	Top						
CT4-230DUAL	JT4H	Up to 1,100	14 1/2 (36.8)	Adjustable up to 1 1/2 (3.8)	Adjustable 1 1/2 - 3 (3.8 - 7.6)	220-240	4950	19.8	50/60	75 (34)	Stripped Ends

* Slices per hour is based on maximum conveyor speed. Conveyor speed determines toasting time and affects color and texture of the toast. Results may vary based upon type of bread, color and texture preference.

The Vollrath Company, L.L.C. Headquarters
1236 North 18th Street
Sheboygan, Wisconsin
53081-3201 USA
Main Tel: 800-624-2051 or 920-457-4851
Main Fax: 800-752-5620 or 920-459-6573
Canada Customer Service: 800-695-8560
Tech Services: techservicereps@vollrathco.com
www.vollrath.com

Pujadas
Ctra. de Castanyet,
132 P.O. Box 121
17430 Santa Coloma de Farners
(Girona) - Spain
Tel. +34-972-84-32-01
info@pujadas.es

Vollrath of China
Vollrath Shanghai Trading Limited
Room 201, Building A
Xin Yi Plaza
1618 Yi Shan Road
Shanghai, 201103
China, P.R.C.
Tel: +86-21-5058-9580

Vollrath de Mexico S. de R.L. de C.V.
Periferico Sur No. 7980 Edificio 4-E
Col. Santa Maria Tequepexpan
45600 Tlaquepaque, Jalisco | Mexico
Tel: (52) 333-133-6767
Tel: (52) 333-133-6769
Fax: (52) 333-133-6768