

item #
model #
project #
sis #
aia #



CSD001E

Cook & hold oven
with drawers

CONSTRUCTION FEATURES

- Tightness chamber with radiused corners
- Total thermic insulation with rock or glass wool
- Long lasting drawers seals made up of food grade of high heat resistance
- Static heating provided by low consumption wire heating element that coils up all the chamber
- Handles to carry by hand
- Ergonomic and fully built-in drawers handle with magnetic closure

FUNCTIONAL FEATURES

- Electronic control of the time, temperature and core probe
- Operating temperature 30° ÷ 120°C
- Two adjustable humidity vents: on the drawer and rear wall
- Designed for stacking
- Chamber with safety thermostat

STANDARD SUPPLY

- Removable GN1/1 tray racks
- Internal core probe

MODULINESRL

Via dell'Industria 11, Z.I. San Giacomo di Veglia 31029 Vittorio Veneto (TV) - ITALY
tel. +39 0438 5063 - fax +39 0438 912 323 - info@moduline.it - www.moduline.it



moduline

TECHNICAL INSTALLATION DIAGRAM

Electricity supply
cable inlet 

Adjustable vent
for release of
excess humidity 

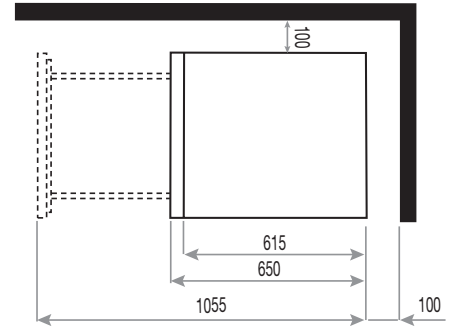
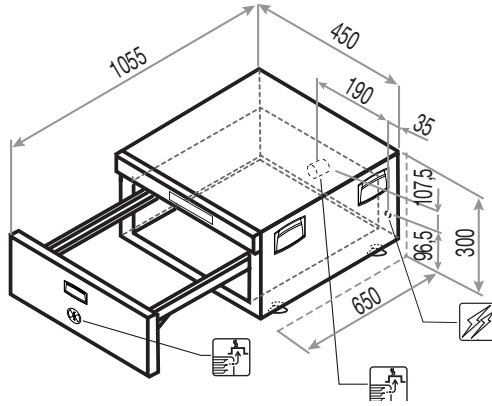

| | | | |
|---|------------------|--------------------------------------|----------------|
| Overall dimensions (W x D x H) - mm | 450 x 650 x 300h | Working temperature [°C] | 30÷120 |
| Trays capacity | 1 GN 1/1 (150h) | Containers capacity distance [mm] | 1 GN 1/1 (150) |
| Power kW | 0,7 | Containers max height [mm] | 150 (h) |
| Power supply | AC 230V 50 Hz | Product max capacity [kg] | 6 |
| Rated voltage [Vac] | 230 | Net weight | 31 |
| Total input [Kw] | 0,7 | | |
| Amps. [A] | 3,1 | | |
| Connecting wire min. section (type H07 RN-F) [mm ²] | 3 x 1 | | |

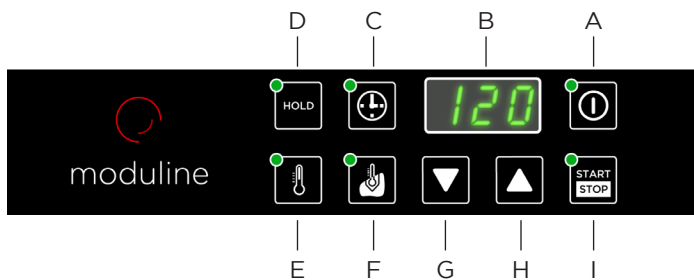

- A ON/OFF switch
- B Display
- C Time selection key
- D Keeping warm or regenerating mode programming keys
- E Temperature selection key
- F Core probe on/off key
- G Temperature decrease key
- H Temperature increase key
- I START/STOP key

MODULINESRL

Via dell'Industria 11, Z.I. San Giacomo di Veglia 31029 Vittorio Veneto (TV) - ITALY
tel. +39 0438 5063 - fax +39 0438 912 323 - info@moduline.it - www.moduline.it