

HMB HOT 160

Mibrasa® oven with heated holding drawers



FEATURES

OUR CHARCOAL OVENS **hot** WITH HEATED HOLDING DRAWERS

MIBRASA® is a closed grill invented and made in our work-shops. Made from the best quality steel by expert hands, our grills are designed to satisfy even the most demanding chefs.

The technical specifications allow the user to accurately control the air flow through the grill, changing the intensity of the embers. This is an extremely efficient way of cooking and cuts down the amount of charcoal needed.

With the HOT series take full control by optimizing the residual heat from the Mibrasa® oven to hold ingredients in three temperature zones on the unit. The seamless lineal design makes the MIBRASA® HOT the most comprehensive charcoal oven station for any chef that prioritizes an effective and cost-efficient kitchen.

TECHNICAL INFORMATION

Fire up time ¹	45 min-average
Cooking temperature	250 - 350 °C
Initial charcoal load ¹	18 kg
Production*	120 kg/h
Charcoal load duration ²	8 h
Equivalent power*	6 kW
Exhaust rate	3500 m ³ /h
Firebreak diameter	Ø154 mm
Duct diameter	Ø114 mm
Crated size (WxDxH)	1100 x 1100 x 1900 mm

*Approximate data

1. Consult instruction manual
2. Will vary depending on quality of charcoal
3. Weight with accessories included

DINERS
PER SERVICE*



GRILL DIMENSIONS

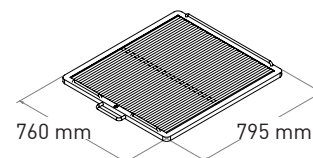

INCLUDED ACCESSORIES

- Grill [G160]
- Oven tongs [TG]
- Ash shovel [PALA]
- Ember poker [PK160]
- Grill brush [CEP]
- Mibrasa Ecofire firelighters [FL]
- GN 1/1 Mibrasa
- GN 1/2 Mibrasa

OPTIONAL ACCESSORIES

- Extra grill [G160]
- Firebreak [FB]
- Dissipating filter [DF]
- Casters [WINOX]
- Kitchenware (consult online catalogue)
- Grillware (consult online catalogue)

Specifications and design are subject to change without notice.

QUALITY GUARANTEE



Rev. 3/22

Mibrasa® Charcoal Ovens S.L

C/Joan Rovira i Bastons, 26

17230 Palamós - Spain

+34 972 601 942 - mibrasa@mibrasa.com

www.mibrasa.com



HMB HOT 160

Mibrasa® oven with heated holding drawers

SIDE VIEW

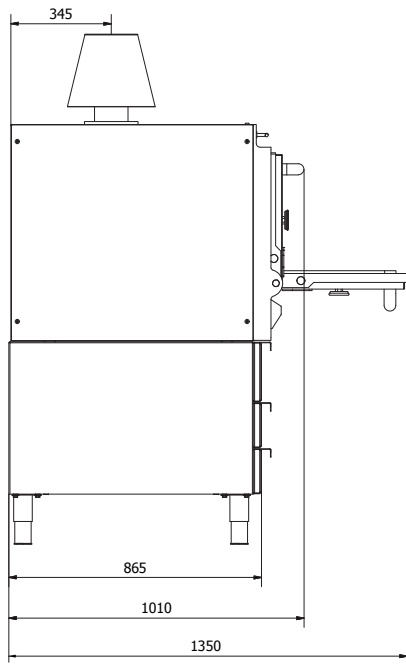

FRONT VIEW

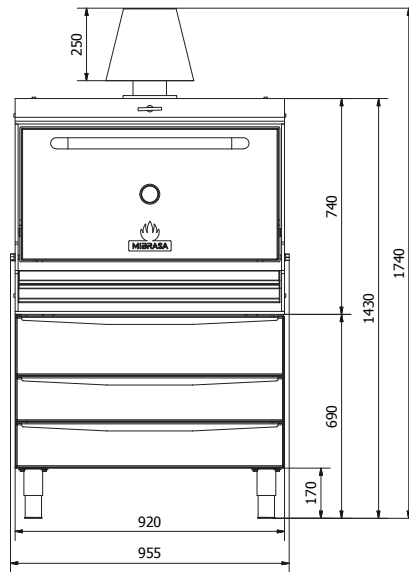

DOOR COLOUR



Dimensions in mm

* Adjustable leg height: 135-195 mm

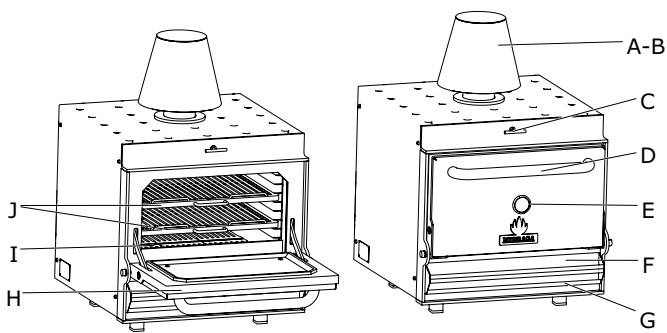

A	Firebreak
B	Dissipating filter
C	Upper damper
D	Door handle
E	Thermometer
F	Lower d/ash collector
G	Grease collector
H	Door
I	Charcoal grids
J	Grills

GN CAPACITY PER DRAWER

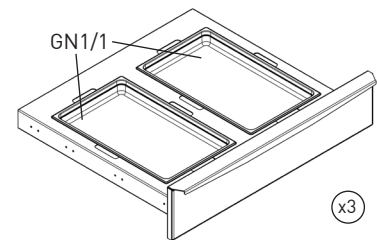

*Residual temperatures of the drawers between 55-90°C based on oven working at 300°C.

INSTALLATION GUIDELINES AND SAFETY STANDARDS

Recommended installation height	-
Clearances to construction/other appliances from oven	76 mm
Clearances of flammable materials from oven	300 mm
Clearance of workspace from front of the oven	1100 mm



*It is recommended to use a lifting device to lift the oven and place on the heating drawers.

Specifications and design are subject to change without notice.