



## Features

### **Dual Zone Temperature Control**

Dual zoned top and bottom heaters create the perfect holding environment for each menu item

### **Durable Construction**

Durable stainless steel construction for longer lasting equipment life

### **Removable Metal Lids**

Increases thermal conductivity to extend product hold times

### **Rackless Design**

Fewer parts to clean and maintain simplifying the overall cleaning process

### **Single-Sided and Pass-Through Design**

Configurations available in single-sided and pass-through design for maximum application flexibility

### **Wide Range of Sizes and Configurations**

Choose up to 5 different sizes

### **All-Day Menu Variety**

Up to six different daypart menu options

### **Simple Menu Selection and Upload**

USB port included for easy upload of new menus

### **Digital Display**

Digital display front and back timer bars available

### **Cook More Alert**

Never run out of food with alerts that notify when to cook more product

### **Ethernet Connectivity**

Connect to Kitchen Management Systems (KMS) and compatible with Sicom Chef™

### **Troubleshooting Errors**

Easy to understand error codes to help troubleshooting and maintenance

### **Warranty**

1-year parts and labor warranty including on-site service

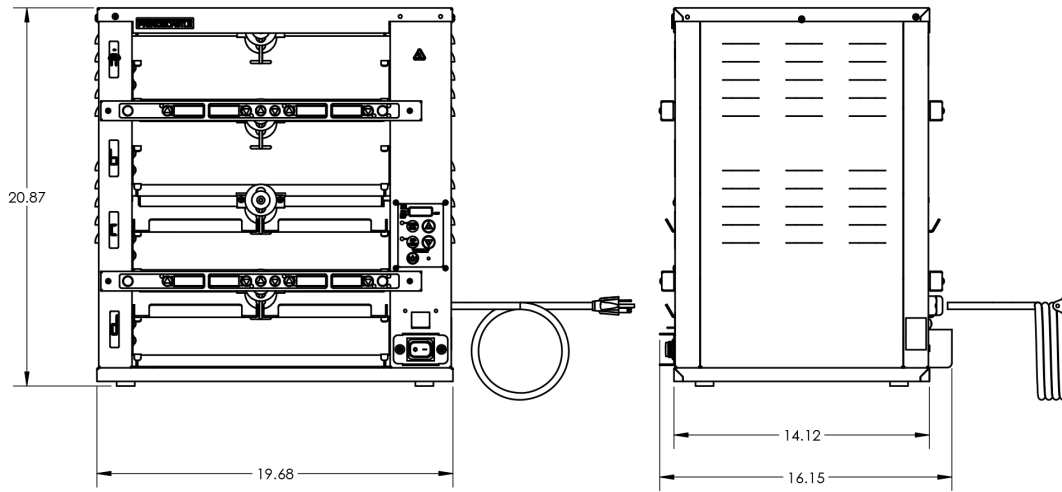

## Technical Specifications

<b>Product Category</b>	Extended Holding Bin (EHB)
<b>Product Dimensions</b>	19.7" L x 14.1" W x 20.6" H (500mm x 358mm x 523mm)
<b>Power Requirements</b>	10-120V, 60Hz 208-240V, 50/60Hz
<b>Bin Design</b>	Single-Sided Pass-Through
<b>Bin Capacity</b>	(8) 1/3 Size Pans
<b>Exterior Construction</b>	Stainless steel with anti-slip legs

<b>Unit Weight</b>	57 lbs (25.8 kg)
<b>Shipping Weight</b>	94 lbs (43 kg)
<b>Shipping Dimensions</b>	25" L x 23.5" W x 26" H (635mm x 597mm x 660mm)
<b>Warranty</b>	1-year parts and labor <i>including on-site service</i>
<b>Agency Listing</b>	

Model Number	Description
EHB42R1-GMS02	Extended Holding Bin 4x2 pass-through, 110-120V, 1440-1680W, 13.1-14.0A, 60Hz, NEMA 5-20P, USA/CA
EHB42F1-GMS02	Extended Holding Bin 4x2, single-sided, 110-120V, 1440-1680W, 13.1-14.0A, 60Hz, NEMA 5-20P, USA/CA
EHB42R2-GMS60	Extended Holding Bin 4x2, pass-through, 208-240V, 1600-2100W, 7.7-8.8A, 50/60Hz, Schuko, UK/EU
EHB42F2-GMS60	Extended Holding Bin 4x2, single-sided, 208-240V, 1600-2100W, 7.7-8.8A, 50/60Hz, Schuko, UK/EU
EHB42R2-GMS78	Extended Holding Bin 4x2, pass-through, 208-240V, 1600-2100W, 7.7-8.8A, 50/60Hz, BS1363A, UK/MID EAST
EHB42F2-GMS78	Extended Holding Bin 4x2, single-sided, 208-240V, 1600-2100W, 7.7-8.8A, 50/60Hz, BS1363A, UK/MID EAST

*Note: Pans not included*

To learn more about **Prince Castle EHB Holding Bins**, visit [princecastle.com](http://princecastle.com)  
 To contact a Prince Castle representative, go to [princecastle.com/contact/](http://princecastle.com/contact/)