



50Hz

Indigo[®] NXT™ iT1900 Ice Cube Machine

iT1900 on D970 Storage Bin

- Ⓐ Electrical Entrance (2) Options
- Ⓑ 1/2" (1.27 cm) F.P.T. Water Condenser Outlet (water-cooled units)
- Ⓒ 3/8" (0.95 cm) F.P.T. Water Condenser Inlet (water-cooled units)
- Ⓓ 3/8" (0.95 cm) F.P.T. Ice Making Water Inlet
- Ⓔ 1/2" (1.27 cm) F.P.T. Ice Making Water Drain
- Ⓕ 1/2" (1.27 cm) Auxillary Base Drain Socket
- Ⓖ 3/4" (1.91 cm) Bin Drain

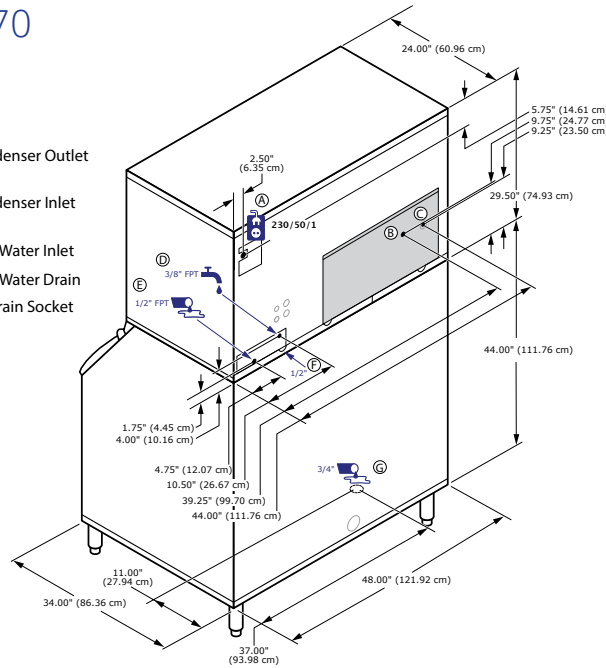

Installation Note
Air Cooled clearance:
 Top: 24" (61.0 cm)
 Sides: 24" (61.0 cm)
 Back: 5" (30.5 cm)
Water Cooled clearance:
 Top/Sides: 8" (20.3 cm)
 Back: 5" (12.7 cm)

Space-Saving Design



	iT1900 D970
Height	79.50" 201.90 cm
Width	48.00" 121.92 cm
Depth	34.00" 86.30 cm
Bin Storage	710lbs 322.2 kgs

Height includes adjustable bin legs 6.00" to 8.00", (15.24 to 20.32 cm) set at 6.00" (15.24 cm).

Specifications

	Model	Ice Shape	Ice Production 24 Hours		Power Usage kWh 45.4 kg / 100 lbs @ 32° Air / 21°C Water 90°Air/70°F Water	Potable Water Usage/100 lbs. 45.4 kgs. of Ice
			21°Air / 10°C Water 70°Air/ 50°F Water	32°Air / 21°C Water 90°Air/ 70°F Water		
AIR-COOLED	IRT1900A	regular	1,728 lbs.	1,248 lbs.	4.68	20 Gal. 75.7 L
			784 kgs	566 kgs		
	IDT1900A	dice	1,825 lbs.	1,355 lbs.	4.64	20 Gal. 75.7 L
REMOTE-COOLED	IYT1900A	half-dice	1,835 lbs.	1,400 lbs.	4.48	20 Gal. 75.7 L
			832 kgs	635 kgs		
IDT1900N	dice	1,755 lbs.	1,475 lbs.	4.08	20 Gal. 75.7 L	
		796 kgs	669 kgs			

Order separately: Ice storage bin for all units, line-set and remote condenser unit JCT1500 for remote cooled units. This product is hermetically sealed and contains fluorinated greenhouse gas R410A

Accessories

LuminIce[®] II Growth Inhibitor
 reduces yeast and bacteria growth for a cleaner ice machine.



External Scoop holder
 Protect the ice scoop with the NSF approved versatile scoop holder.

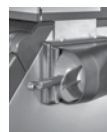

Arctic Pure[®] Water Filters
 Reduces sediment and chlorine odors for better tasting ice.



Welbilt reserves the right to make changes to the design or specifications without prior notice.

Welbilt Deutschland GmbH
 Auf der Weih 11
 D - 35745 Herborn, Germany
 Tel.: +49 27 72 58 050
 welbilt.com.de

Welbilt Iberia, S.A.U
 Textil, 6 - Pol.Ind. La Ferreria - 08110
 Montcada i Reixac
 Barcelona, Spain
 Tel.: +34 902 20 10 69
 welbilt.com.es

Welbilt UK
 Ashbourne House The Guildway,
 Old Portsmouth Rd Guildford GU3
 1L United Kingdom
 Tel.: +44 1483 464900
 www.welbilt.uk

