

Cook & Hold Oven

Model 1000-SK

ALTO-SHAAM

Smoker Ovens effortlessly infuse bold flavors with real wood chips. No pressure-cooking or artificial smoke flavor required.

Gentle, low and slow Halo Heat® technology evenly surrounds food without the use of extremely hot elements, added humidity or fans. This controlled, uniform heat maintains precise temperatures throughout the hot smoking, cooking and holding process—improving food quality and extending hold times.

Cook by time or probe with simple or deluxe controls. Probes sense internal product temperature and automatically convert the oven from cook mode to hold mode once set parameters have been reached.

Labor-free, overnight smoking, cooking and holding paired with effortless operation reduces labor costs and increases productivity.

Advanced controls – designed intentionally simple – feature an intuitive, user-friendly interface and programmable recipes to ensure consistency with each cook.

ChefLinc™, cloud-based remote oven management software, streamlines processes and maximizes profits with data-driven insights [deluxe control only].

ISO 9001:2015-certified.

Standard Features

- Casters [two (2) rigid, two (2) swivel with brake]
- Single-point, straight removable probe
- Drip tray and drip pan with drain
- Programmable, touchscreen control on Deluxe model
- Programmable control on Simple model
- HACCP data collection on Deluxe model
- Easy recipe upload/download via USB port
- SureTemp™ heat recovery on Deluxe model
- Two (2) stainless steel side racks with fifteen (15) pan positions spaced 36mm on centers
- Removable exterior drip tray
- Woodchip tray and sample bag of woodchips



7 GN 1/1 — 530mm x 325mm x 65mm

14 GN 1/2 — 265mm x 325mm x 65mm

Weight maximum: 54 kg

Volume maximum: 56.8 liters

Three (3) shelves included. Additional shelves required for maximum capacity.

CE EAC IP X4



Lifetime Warranty

On all Cook & Hold heating elements [excludes labor]



1000-SK

Shown with Deluxe control

Configurations (select one each)

Models

- Simple
- Deluxe
 - Ethernet option (5032090)

Door Choice

- Right hinged, solid door, standard
- Right hinged, window door
- Left hinged, solid door
- Left hinged, window door

Special Probe Configuration (if applicable)

- Multi-point probe (5017133)

Electrical

- 120V, 1Ph
- 208-240V, 1Ph
- 230V, 1PH

Casters and Legs

- 64mm casters, two (2) rigid two (2) swivel with brake, standard (5027134) – not available with bumper
- 89mm casters, two (2) rigid two (2) swivel with brake, option (5027133)
- 127mm casters, two (2) rigid two (2) swivel with brake, option, (5027112)
- 152mm legs, set of four (4)
- 152mm seismic legs, set of four (4)

Optional Accessories (select all that apply)

Bumper and Handles

- Full perimeter bumper
- Push/Pull handle kit

Additional Probes

- Sous vide probe (PR-36576)
- T-handle probe, up to six (6) with Deluxe (PR-46998)
- Straight probe, up to six (6) with Deluxe (qty one (1) included with oven) (PR-46999)

Drip Pans, Shelves, Holders

- Drip pan with drain (5025893)
- Drip pan, without drain (1034371)
- Increased capacity exterior drip pan (5030659)
- Shelf, stainless steel (SH-2325)
- Carving holder, prime rib (HL-2635)
- Carving holder, steamship (cafeteria round) (4459)

Cleaners

- Alto-Shaam, non-caustic cleaner one (1) 32-ounce bottle (CE-46828)
- Alto-Shaam, non-caustic cleaner six (6) 32-ounce bottles (CE-46829)

Accessories, misc.

- Stacking kit, 1000-TH over 1000-TH (5032046)
- Door lock with key (5028755)
- HACCP data logger, for Simple control (standard on Deluxe control)

Woodchips, 0.9 kg bag

- Cherry (WC-22540)
- Maple (WC-22544)
- Apple (WC-22542)
- Hickory (WC-2828)

Cook & Hold Oven

Model 1000-SK

ALTO-SHAAM.

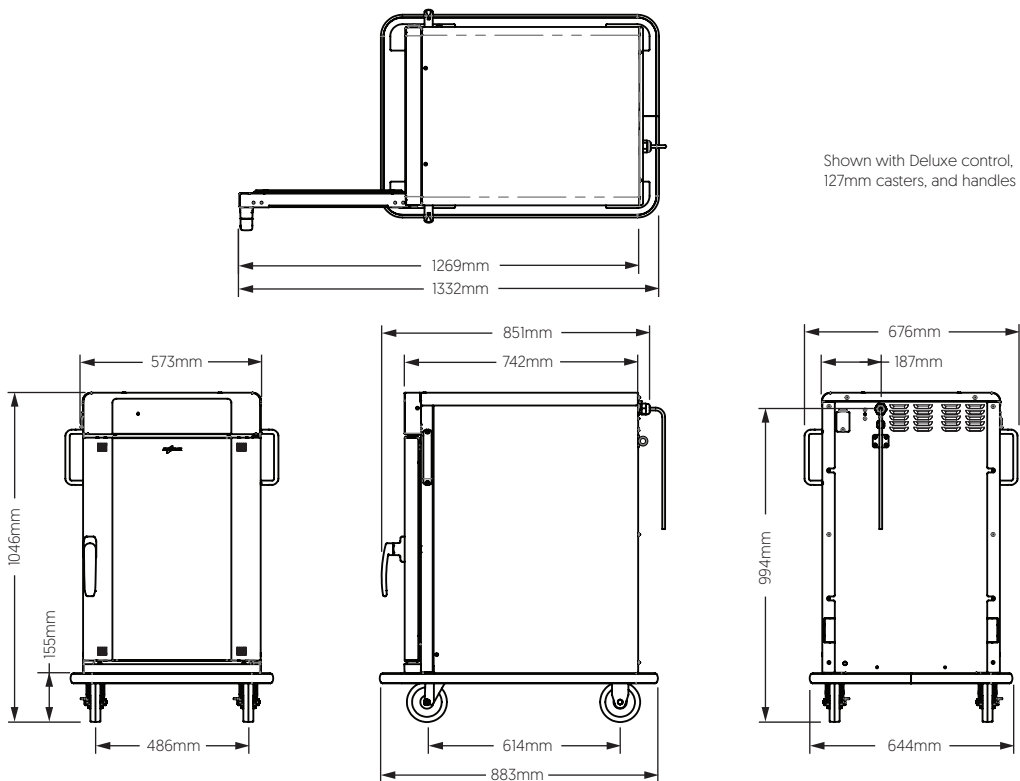
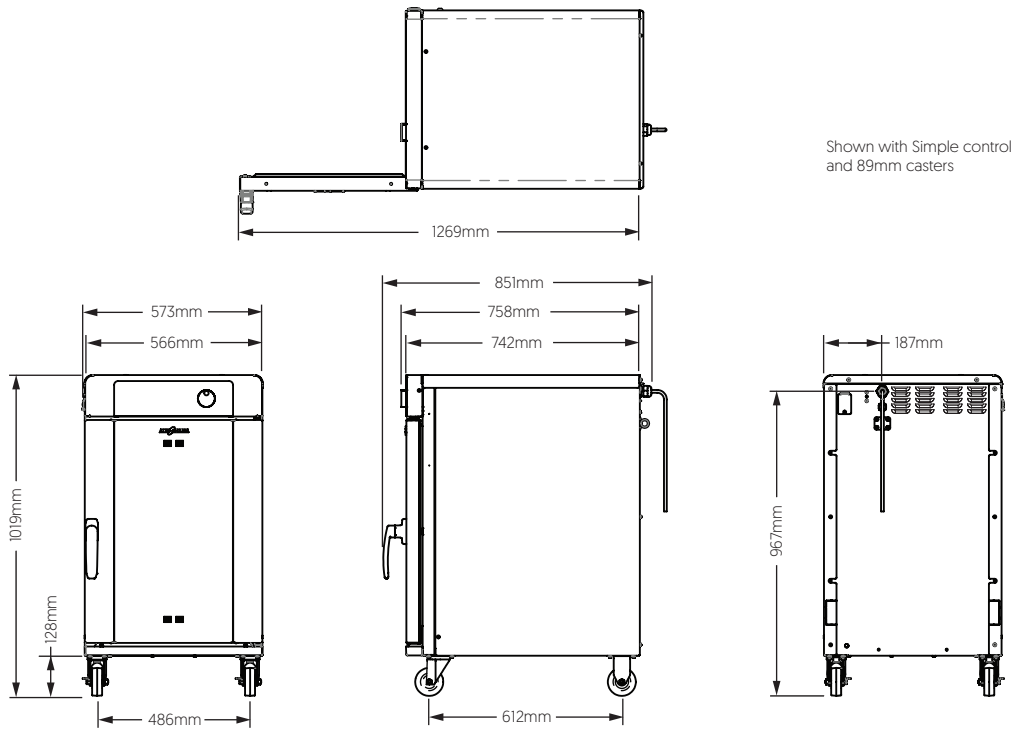

Interior (H x W x D)	Net Weight	Ship Dimensions (L x W x H)	Ship Weight
683mm x 479mm x 673mm	113 kg	991mm x 991mm x 1372mm	143 kg

Cook & Hold Oven

Model 1000-SK



CLEARANCE

Top:..... 51mm
 Left:..... 51mm
 Right:..... 51mm
 Back: 76mm



CHECK FIRST

The oven must be installed level.
 The oven must not be installed in any area where it may be affected by steam, grease, dripping water, high temperatures, or any other severely adverse conditions.

See local installation codes for smoker ventilation requirements.



HEAT

Heat of rejection

1000-SK	Heat Gain qs, BTU/hr	Heat Gain qs, kW
	912	0.27



TEMPERATURE

Cooking temperature range:

94°C–163°C

Holding temperature range:

29°C–96°C



ELECTRIC

1000-SK

1000-SK	V	Ph	Hz	Awg	IEC	A	Breaker (A)	kW	Plug Configuration*	Certification
120V**	120	1	60	12	—	18	20 UL 30 CSA	2.2	No cord, no plug	
208–240V**	208	1	60	12	—	17	20 UL 30 CSA	3.4	No cord, no plug	
	240	1	60	12	—	19	20 UL 30 CSA	4.5		
230V	230	1	50/60	12	—	18	32	4.1	No cord, no plug	

Electrical connections must meet all applicable federal, state, and local codes.

*Additional cord and plug configurations available from factory.

**Dedicated circuit required.

CONTACT US

W164 N9221 Water Street | Menomonee Falls, Wisconsin 53051 | U.S.A.
 Phone: 262.251.3800 | 800.558.8744 U.S.A./Canada | Fax: 262.251.7067 | alto-shaam.com