

500-HW Series Waterless Hot Food Well

ALTO-SHAAM.

Unlike traditional steam tables or dry wells, waterless hot food wells from Alto-Shaam feature radiant Halo Heat® technology that evenly surrounds food without the use of extremely hot elements, added humidity or fans. Extend hold times, maintain food quality and reduce operating costs to maximize return on investment.



500-HW

Standard Features

- Extend food holding times with efficient, precise Halo Heat® technology
- Maintain food quality without the use of extremely hot elements, added humidity or fans
- Increase sales with attractive food presentation and quality
- Reduce installation and operating costs with no water or plumbing needed
- Save on maintenance costs, eliminating lime and scale buildup associated with traditional steam tables
- Increase employee and customer safety with elimination of hot water and steam
- Provide optimal holding temperatures with an adjustable thermostat that can be flush-mounted into the counter or a location out of sight from customers
- Set ideal holding temperatures for any dish with an individual well control option
- HWLF models feature a large flange
- HWI and HWILF models are controlled by two [2] separate adjustable thermostats
- 500-HW/D4, 500-HW/D6, 500-HWLF/D4, and 500-HWLF/D6 models include ten [10] half/third-size divider bars and four [4] large pan divider bars
- 500-HWI/D4, 500-HWI/D6, 500-HWILF/D4, and 500-HWILF/D6 models include ten [10] half/third-size divider bars

Configurations (select one)

- | | |
|---------------------------------------|---------------------------------------|
| <input type="checkbox"/> 500-HW/D4 | <input type="checkbox"/> 500-HW/D6 |
| <input type="checkbox"/> 500-HWLF/D4 | <input type="checkbox"/> 500-HWLF/D6 |
| <input type="checkbox"/> 500-HWI/D4 | <input type="checkbox"/> 500-HWI/D6 |
| <input type="checkbox"/> 500-HWILF/D4 | <input type="checkbox"/> 500-HWILF/D6 |

Electrical

- | | |
|-------------------------------|------------------------------------|
| <input type="checkbox"/> 120V | <input type="checkbox"/> 208V–240V |
| <input type="checkbox"/> 230V | |

Control box cord location

- Back, standard
- Bottom, optional

Accessories (select all that apply)

- Pan divider bar—half-size/third-size [11318]
- Pan divider bar—full-size [16019]
- Locking kit [5020849]



- 5** Five full-size or GN 1/1 pans
10 Ten half-size or GN 1/2 pans
15 Fifteen third-size or GN 1/3 pans
 D4: 120 lb [54 kg] product maximum*
 D4: 72.5 qt [70 L] volume maximum*

*Based on 4" [100mm] deep pans. Will also accept 2-1/2" [65mm] deep pans; D6 hot wells will accept 6" [150mm] deep pans.



IP X3



500-HW Series

Specification

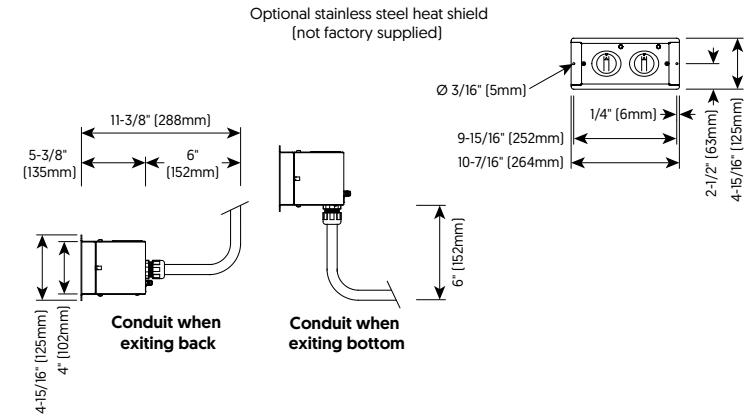
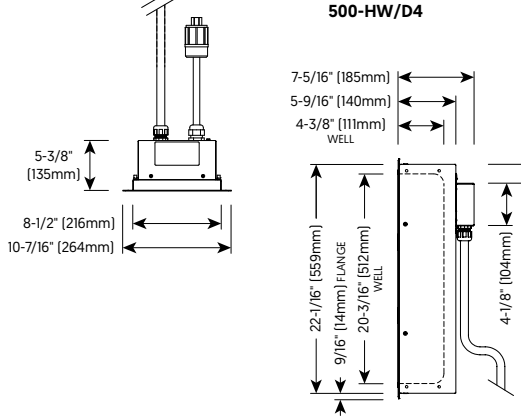
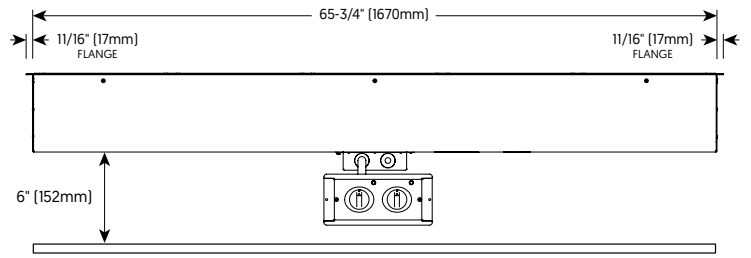
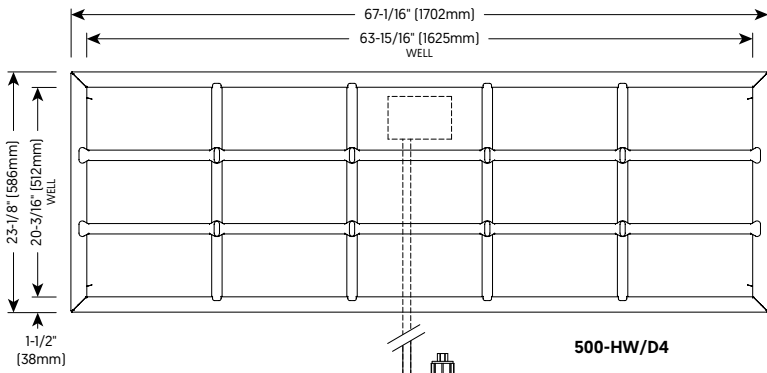

500-HWLF Series

Specification

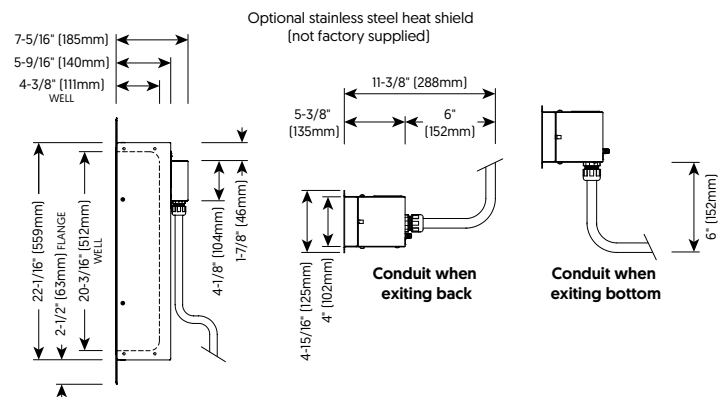
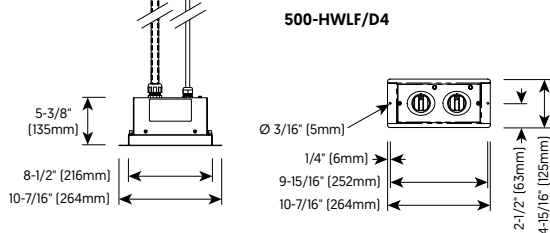
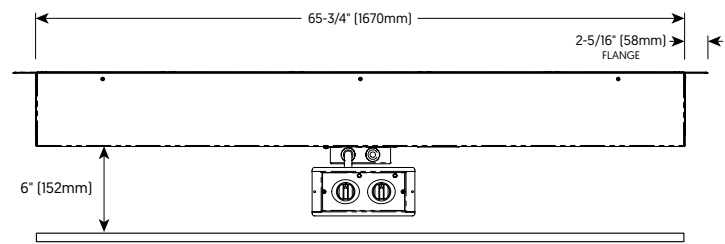
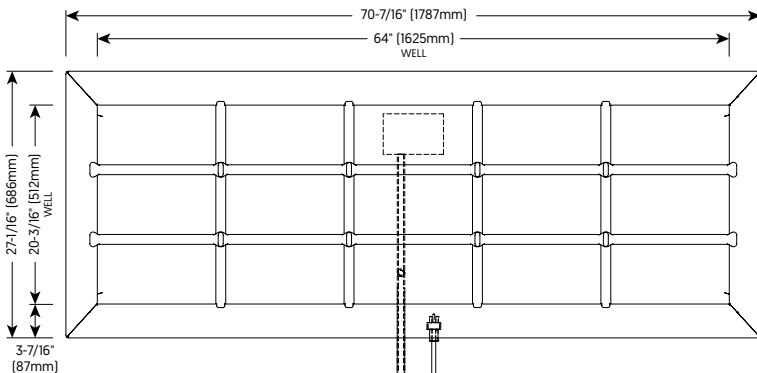

500-HW Series



DIMENSIONS

Model	Exterior (H x W x D)
500-HW/D4	7-5/16" x 67-1/16" x 23-1/8" [185mm x 1702mm x 586mm]
500-HW/D6	9-5/16" x 67-1/16" x 23-1/8" [235mm x 1702mm x 586mm]
500-HWLF/D4	7-5/16" x 70-7/16" x 27-1/16" [185mm x 1787mm x 686mm]
500-HWLF/D6	9-1/4" x 70-7/16" x 27-1/16" [234mm x 1787mm x 686mm]
500-HWI/D4	7-5/16" x 66-13/16" x 23-3/16" [185mm x 1696mm x 588mm]
500-HWI/D6	9-5/16" x 66-13/16" x 23-3/16" [235mm x 1696mm x 586mm]
500-HWILF/D4	7-5/16" x 70-3/8" x 27-1/16" [185mm x 1787mm x 686mm]
500-HWILF/D6	9-5/16" x 70-3/8" x 27-1/16" [225mm x 1787mm x 686mm]

Counter Cutout (W x D)

500-HW/D4	66-1/2" x 22-1/2" [1689mm x 559mm]
500-HW/D6	66-1/2" x 22-1/2" [1689mm x 559mm]
500-HWLF/D4	66-1/2" x 22-1/2" [1689mm x 559mm]
500-HWLF/D6	66-1/2" x 22-1/2" [1689mm x 559mm]
500-HWI/D4	66-1/2" x 22-1/2" [1689mm x 559mm]
500-HWI/D6	66-1/2" x 22-1/2" [1689mm x 559mm]
500-HWILF/D4	66-1/2" x 22-1/2" [1689mm x 559mm]
500-HWILF/D6	66-1/2" x 22-1/2" [1689mm x 559mm]

*Allow 6" [152mm] clearance from control box to conduit bend.

Net Weight

500-HW/D4	85 lb [39 kg]
500-HW/D6	94.5 lb [43 kg]
500-HWLF/D4	89.5 lb [41 kg]
500-HWLF/D6	100 lb [45 kg]
500-HWI/D4	107 lb [49 kg]
500-HWI/D6	121 lb [55 kg]
500-HWILF/D4	115 lb [52 kg]
500-HWILF/D6	128.5 lb [58 kg]

Ship Weight**

125 lb [57 kg]
170 lb [77 kg]
220 lb [100 kg]
175 lb [79 kg]
180 lb [82 kg]
150 lb [68 kg]
Contact factory
150 lb [68 kg]

**Domestic ground shipping information. Contact factory for export weight and dimensions.

Interior (H x W x D)

4-3/8" x 63-15/16" x 20-3/16" [111mm x 1625mm x 512mm]
6-3/8" x 63-15/16" x 20-3/16" [162mm x 1625mm x 512mm]
4-3/8" x 64" x 20-3/16" [111mm x 1625mm x 512mm]
6-3/8" x 64" x 20-3/16" [162mm x 1625mm x 512mm]
4-3/8" x 12" x 20-3/16" [111mm x 304mm x 512mm]
6-3/8" x 12" x 20-3/16" [162mm x 304mm x 512mm]
4-3/8" x 12" x 20-3/16" [111mm x 304mm x 512mm]
6-3/8" x 12" x 20-3/16" [162mm x 304mm x 512mm]

Control Box Cutout (H x W x D)*

4-1/4" x 8-3/4" x 11-3/8" [108mm x 222mm x 288mm]
4-1/4" x 8-3/4" x 11-3/8" [108mm x 222mm x 288mm]
4-1/4" x 8-3/4" x 11-3/8" [108mm x 222mm x 288mm]
4-1/4" x 8-3/4" x 11-3/8" [108mm x 222mm x 288mm]
4-1/4" x 19-1/4" x 11-3/8" [108mm x 489mm x 288mm]
4-1/4" x 19-1/4" x 11-3/8" [108mm x 489mm x 288mm]
4-1/4" x 19-1/4" x 11-3/8" [108mm x 489mm x 288mm]
4-1/4" x 19-1/4" x 11-3/8" [108mm x 489mm x 288mm]

Ship Dimensions (L x W x H)**

72" x 34" x 15" [1829mm x 864mm x 381mm]
72" x 34" x 15" [1829mm x 864mm x 381mm]
72" x 34" x 15" [1829mm x 864mm x 381mm]
72" x 34" x 15" [1829mm x 864mm x 381mm]
72" x 34" x 15" [1829mm x 864mm x 381mm]
72" x 34" x 15" [1829mm x 864mm x 381mm]
72" x 34" x 15" [1829mm x 864mm x 381mm]
72" x 34" x 15" [1829mm x 864mm x 381mm]



CHECK FIRST

- Appliance must be installed level and must not be installed in any area where it may be directly affected by steam, grease, dripping water, high temperatures, or any other severely adverse conditions.
- Some foods may require additional overhead heating. Always monitor the food temperature and add overhead heating when needed.
- Countertop material must withstand temperatures up to 200°F [93°C].
- A stainless steel heat shield is recommended if the area under the appliance is used for storage.



CLEARANCE

1" [25 mm] from combustible surfaces



ELECTRIC

All models	V	Ph	Hz	A	kW	Cord & Plug
120V	120	1	50/60	25.0	3.0	NEMA L5-30p 30A-125V plug
208-240V	208	1	50/60	10.8	2.3	NEMA 6-15p 15A-250V plug
	240	1	50/60	12.5	3.0	
230V	230	1	50/60	12.0	3.0	CEE 7/7 plug rated 250V CH2-16p plug rated 250V BS 1363 plug rated 250V

Cord length: 120V: 6 ft [1.8 m]; 208-240V: 9 ft [2.7 m];
230V (CEE): 9 ft [2.7 m]; 230V (CH, BS): 8 ft [2.5 m]



HEAT

Heat of rejection

500-S	Heat Gain qs, BTU/hr	Heat Gain qs, kW
	304	0.09

CONTACT US

W164 N9221 Water Street | Menomonee Falls, Wisconsin 53051 | U.S.A.
Phone: 262.251.3800 | 800.558.8744 U.S.A./Canada | Fax: 262.251.7067 | alto-shaam.com