

SAG201BS

COMBI STEAMER FOR GASTRONOMY
20 X 1/1 GN
GAS WITH BOILER

MANUAL ELECTRONIC CONTROLS
ASSISTED COOKING
EQUIPPED WITH N. 1 TROLLEY NKS201



3.5-inch (LCD - TFT) colour display for displaying your favourite programs, pre-set programs, variable fan speed, automatic washing, menus, and settings.

WHEN TECHNOLOGY REINVENTS THE PAST



QUICK

Broccoli in just 7 minutes.
24 chickens in 30 minutes (Ref. mod.101)



SMALL

Up to 15% less space by miniaturising the components.



EFFICIENT

Energy monitor. VCS Vapor Clean System, new washing system.
Reduction in detergent consumption up to 30% less.



POWERFUL

With up to 20% more power, it also guarantees faster cooking with full loads which are always perfect. The new energy supply systems result in savings of up to 16% less compared to previous models.



ACCURATE

Stable and accurate temperature at all times thanks to the automatic consumption management. Autoclima controls the ideal climate, thus guaranteeing excellent cooking quality at all times.



STURDY

Long Life Component LLC. New long-lasting components.
EMA Easy Maintenance Access to reduce service intervention times.



EMC



IPX5



General data

Capacity	GN	20 x 1/1 GN	Packing dimensions (W x D x H)	mm	1100 x 1110 x 2040
Distance between layers	mm	63	Weight - Net / Gross	kg	310 / 354,2
Meals - Croissants	n°	150 / 300 - 240	Volume	m ³	2,44
Max. tray load	kg	25	Minimum installation clearance - left side	mm	50
Max. total load	kg	90	Minimum installation clearance - rear side	mm	50
Net external dimensions (W x D x H)	mm	892 x 862 x 1812	Minimum installation clearance - right side	mm	500
Maximum external dimensions (W x D x H)	mm	892 x 966 x 1856			

Power supply

Total electric power	kW	1,3	Chamber heating output	kW / kcal	44 / 37840
Consumption	Amp	5,7	Frequency	Hz	50/60
Power supply voltage	V	1N-AC 230	Differential switch, single-phase frequency converter		RCD cl. B

Gas supply

Gas - Type		G20 - G30 - G31	Max. gas pressure - G20	bar	0,025
Gas versions nominal heating output - G20	kW / kcal	44 / 37840	Gas versions nominal heating output - G20 (with steam generator)	kW / kcal	52 / 44720
Convection heating output - G20	kW / kcal	44 / 37840	Steam heating output (with steam generator)	kW / kcal	32 / 27520
Min. gas pressure - G20	bar	0,018			

Water Connection

Cold water inlet	∅ - inch.	3/4	Discharge	∅ - mm	50
Softened water inlet	∅ - inch.	3/4	Minimum water flow	l / min	10
Min. pressure	bar	2	Drainage slope		4°
Max. pressure	bar	5			

Water quality

Water hardness for steam generation connection	°dh / ppm	6° / 9° fH	NH ₂ Cl (monochloramine)	mg / l	0,2
pH value	Ph	> 7,5	Max. cold water temperature	°C	30
Cl (chloride) - max	mg / l	30 mg/l max	Max. softened water temperature	°C	50
Cl ₂ (free chlorine)	mg / l	0,1 mg/l max	Electrical conductivity	µs	50 - 200
Fe (iron)	mg / l	0,1 mg/l max			

Emissions

Latent heat	W / kW	234	Max. liquid discharge temperature	°C	85
Sensitive heat	W / kW	195	Noisiness	db	< 50

Special voltages and frequencies on request.

COOKING MODES

- AUTOMATIC WITH 95 TESTED AND STORED COOKING PROGRAMMES, INCLUDING PROGRAMMES FOR REHEATING ON THE PLATE OR IN THE PAN.
- PROGRAMMABLE WITH THE ABILITY TO STORE 99 COOKING PROGRAMMES IN AUTOMATIC SEQUENCE (UP TO 9 CYCLES), ASSIGNING A NAME AND DEDICATED ICON.
- MANUAL MODE WITH THREE COOKING MODES AND INSTANT COOKING START: CONVECTION FROM 30°C TO 300°C, STEAM FROM 30°C TO 130°C, COMBINATION CONVECTION + STEAM FROM 30°C TO 300°C.
- RAPID SELECTION OF FAVOURITE PROGRAMS USING SCROLL & PUSH, WITH THE DEDICATED SCROLLER.
- AUTOCLIMA® - SYSTEM THAT AUTOMATICALLY MANAGES THE PERFECT CLIMATE IN THE COOKING CHAMBER.
- FAST-DRY BOOSTED® - AUTOMATIC SYSTEM FOR QUICK DEHUMIDIFICATION OF THE COOKING CHAMBER.

OPERATION

- LED HVS (HIGH VISIBILITY SYSTEM) ALPHANUMERIC DISPLAY TO DISPLAY THE TEMPERATURES, AUTOCLIMA, TIME AND CORE TEMPERATURE.
- 3.5-INCH (LCD - TFT) COLOUR DISPLAY FOR DISPLAYING YOUR FAVOURITE PROGRAMS, PRE-SET PROGRAMS, FAN, AUTOMATIC WASHING, MENUS AND SETTINGS.
- SCROLLER KNOB WITH SCROLL AND PUSH FUNCTION FOR CONFIRMING CHOICES.
- LED BARS TO SIGNAL THAT THE TEMPERATURE, TIMER AND PROBE TEMPERATURE ARE ACTIVATED.
- MANUAL PRE-HEATING.
- COOL DOWN FUNCTION FOR THE RAPID FAN-COOLING OF THE COOKING CHAMBER.
- AUTOMATIC RESUMPTION OF COOKING IN CASE OF A POWER FAILURE.
- RAPID COOLING WITH POSSIBLE INJECTION OF WATER INTO THE COOKING CHAMBER.
- MANUAL HUMIDIFIER.
- ACOUSTIC AND VISUAL SIGNALLING DURING THE VARIOUS STAGES OF COOKING, WITH A FLASHING LIGHT AT THE END OF THE CYCLE.
- USER INTERFACE WITH A CHOICE OF 29 LANGUAGES.
- POSSIBILITY TO VIEW AND MODIFY THE RECIPE AT ANY TIME.

CONTROL MECHANISMS

- AUTO REVERSE (AUTOMATIC REVERSE OF FAN ROTATION) FOR PERFECT COOKING UNIFORMITY.
- EASY ACCESS TO PROGRAMMABLE USER PARAMETERS TO CUSTOMISE THE APPLIANCE THROUGH THE USER MENU.
- AUTOMATICALLY REGULATED STEAM CONDENSATION.
- ABILITY TO CHOOSE UP TO 6 FAN SPEEDS; THE FIRST 3 SPEEDS AUTOMATICALLY TRIGGER A REDUCTION IN HEATING POWER. FOR SPECIAL COOKING METHODS, YOU CAN USE AN INTERMITTENT SPEED.
- TEMPERATURE CONTROL AT THE PRODUCT CORE USING PROBE WITH 4 DETECTION POINTS.
- MULTIPOINT CORE PROBE WITH EXTERNAL CONNECTOR, Ø 3 MM.
- USB CONNECTION TO DOWNLOAD HACCP DATA, UPDATE SOFTWARE AND LOAD/DOWNLOAD COOKING PROGRAMMES.
- POSSIBILITY OF SETTING COMBI SWITCH-OFF AT THE END OF THE AUTOMATIC WASH PROGRAM.
- PRE-CONFIGURED SN ENERGY OPTIMISATION SYSTEM (OPTIONAL).
- SERVICE PROGRAM: TESTING THE OPERATION OF THE ELECTRONIC BOARD - DISPLAY OF THE TEMPERATURE PROBES - COUNTER FOR OPERATING HOURS OF ALL PRIMARY FUNCTIONS FOR PROGRAMMED MAINTENANCE.
- SELF-DIAGNOSIS BEFORE STARTING TO USE THE EQUIPMENT, WITH DESCRIPTIVE AND AUDIBLE SIGNALLING OF ANY ANOMALIES.
- LOW CONSUMPTION LED COOKING CHAMBER LIGHTING. OPTIMAL VISIBILITY IN ALL POINTS OF THE COOKING CHAMBER. NEUTRAL LIGHT THAT DOESN'T ALTER THE ORIGINAL COLOURS OF THE PRODUCT.
- ECOVAPOR - WITH THE ECOVAPOR SYSTEM, THERE IS A NET REDUCTION IN WATER AND ENERGY CONSUMPTION DUE TO THE AUTOMATIC CONTROLS OF THE STEAM SATURATION IN THE COOKING CHAMBER.
- INTELLIGENT ENERGY SYSTEM - BASED ON THE QUANTITY AND TYPE OF PRODUCT, THE OVEN OPTIMISES AND CONTROLS THE ENERGY OUTPUT, MAINTAINING THE BEST COOKING TEMPERATURE AND AVOIDING FLUCTUATIONS.

CONSTRUCTION

- FULL AISI 304 COMBI.
- COOKING CHAMBER IN 1 MM THICK 18/10 AISI 304 STAINLESS STEEL WITH LONG FULLY ROUNDED EDGES FOR BEST AIR FLOW AND EASIER CLEANING.
- PERFECTLY SMOOTH, WATERTIGHT CHAMBER.
- DOOR WITH REAR VENTILATED DOUBLE TEMPERED GLASS WITH AIR CHAMBER AND INTERIOR HEAT-REFLECTING GLASS FOR LESS HEAT RADIATION TOWARDS THE OPERATOR AND GREATER EFFICIENCY.
- INTERNAL GLASS THAT FOLDS TO OPEN FOR EASY CLEANING.
- DOOR WITH THREE LOCKING POINTS. HANDLE BRAKE IN OPEN DOOR POSITION.
- ADJUSTABLE HINGE FOR OPTIMAL SEAL.
- DEFLECTOR THAT CAN BE OPENED FOR EASY FAN COMPARTMENT CLEANING.
- NEW PUSH-IN ADAPTABLE DOVE-TAIL JOINT SEAL FOR OVEN FRONT PANEL MADE WITH HEAT AND AGE RESISTANT SILICON RUBBER, EASY TO REPLACE.
- NEW OVEN DRAIN WITH BUILT-IN AIR GAP IN ACCORDANCE WITH STANDARD EN61770.
- FRONT REMOVABLE CONTROL PANEL FOR EASY SERVICING.
- TWO WATER INLETS (SOFT AND COLD WATER).
- COMPACT BRUSHLESS MAGNETIC DRIVE MOTORS.
- SOLID STATE RELAY FOR POWER OPTIMISATION AND MODULATION.
- LONG LIFE COMPONENT LLC - USE OF NEW LONG-LASTING COMPONENTS.
- LONG LIFE GASKET - LLG. AUTOMATIC ELECTROMAGNETIC TRACKED FRAME HOLD AND RELEASE SYSTEM TO PRESERVE THE SEAL OF THE STOP GASKET.

GAS OPERATION

- COOKING CHAMBER HIGH-PERFORMANCE INDIRECT GAS HEATING SYSTEM WITH PREMIXED AIR-BLOWN MODULATING FLAME BURNERS.
 - AUTOMATIC FLAME IGNITION.
 - ELECTRONIC CONTROL OF THE FLAME WITH AUTOMATIC IGNITION RESET.
 - HIGH EFFICIENCY HEAT EXCHANGER WITH STEEL EXPANSION CABINET.
-

STEAM GENERATION - INDIRECT (WITH STEAM GENERATOR)

- NEW FULLY INSULATED STEAM GENERATOR IN AISI 316 STAINLESS STEEL.
- STEAM GENERATOR HIGH-PERFORMANCE INDIRECT GAS HEATING SYSTEM WITH NEW AIR-BLOWN MODULATING FLAME BURNERS.
- AUTOMATIC BOILER PRE-HEATING.
- DAILY AUTOMATIC BOILER DRAINING AND RINSING, TEMPERATURE OF DRAINED WATER BELOW 60°C.
- ALARM IN CASE OF BOILER DE-SCALING REQUIRED.
- BOILER SEMI-AUTOMATIC DE-SCALING PROGRAM.
- CAL-OUT SYSTEM TO PREVENT SCALE BUILD-UP WITHIN THE BOILER, AS STANDARD.

SAFETY FEATURES

- COOKING CHAMBER TEMPERATURE LIMITER.
- COOKING COMPARTMENT SAFETY DEVICE FOR PRESSURE BUILT-UP AND DEPRESSION.
- FAN MOTOR THERMIC PROTECTION.
- DOOR OPEN/CLOSED ELECTRONIC SENSOR.
- ELECTRONIC CONTROL FOR LACK OF WATER ALARM.
- SELF-DIAGNOSIS WITH SMART ERROR VIEWING.
- VENTILATED COMPONENT COOLING SYSTEM WITH ELECTRONICALLY CONTROLLED OVER-TEMPERATURE DISPLAY.
- ELECTRONIC FLAME DETECTION SENSOR THAT INTERRUPTS THE GAS FLOW IF THE BURNER FLAME IS ACCIDENTALLY SWITCHED OFF.
- SAFETY PRESSURE SWITCH FOR LACK OF GAS ALARM.
- ELECTRONICALLY CONTROLLED TWO-STAGE GAS VALVES.
- STEAM GENERATOR TEMPERATURE LIMITER.
- AUTOMATIC ELECTRONIC CONTROL OF WATER LEVEL IN THE STEAM GENERATOR DURING FILLING AND DRAINING.
- BOILER PROBE TO CHECK BOILER COMPLETELY EMPTY.
- GAS SHORTAGE-SAFETY PRESSURE SWITCH.
- FAN MOTOR BRAKE.
- MAXIMUM EXTERNAL DOOR FRONT TEMPERATURE OF 65°C.
- COMPLIES WITH NATIONAL AND INTERNATIONAL STANDARDS FOR SAFE OPERATION IN CASE OF USE WITHOUT DIRECT OPERATOR SUPERVISION - IEC 60335-1 / IEC 60335-2-102 - EN203-1 / EN203-2-2
- MAXIMUM LAST TRAY SHELF HEIGHT 160 CM.
- IN CASE OF A POWER FAILURE DURING WASHING, HYGIENE IS ALWAYS GUARANTEED INSOFAR AS THE WASHING CYCLE IS AUTOMATICALLY RESUMED.

CLEANING AND MAINTENANCE

- VCS - VAPOR CLEAN SYSTEM. NEW AUTOMATIC WASHING SYSTEM WITH VAPORISATION OF THE DETERGENT IN THE COOKING CHAMBER. ALLOWS A SIGNIFICANT REDUCTION IN DETERGENT CONSUMPTION UP TO 30% (PATENT PENDING).
INTERNAL HOUSING FOR DETERGENT CARTRIDGE WITH AUTOMATIC DISPENSING (COMBICLEAN CDL05, LIQUID DETERGENT, IN 100% RECYCLABLE CARTRIDGES).
SUPPLIED WITH 1 CARTRIDGE OF LIQUID DETERGENT CDL05 - 990 GR.
- CALOUT DESCALING SYSTEM THAT PREVENTS THE FORMATION AND ACCUMULATION OF LIMESCALE IN THE STEAM GENERATOR. INTERNAL HOUSING FOR DESCALER CARTRIDGE WITH AUTOMATIC DISPENSING (CALFREE CCF05 LIQUID DESCALER, IN 100% RECYCLABLE CARTRIDGES).
SUPPLIED WITH 1 CARTRIDGE OF LIQUID DESCALER CCF05 - 990 GR.
- WMS - WASH MANAGEMENT SYSTEM. SYSTEM ALLOWING WASHING PROGRAMMES TO BE PLANNED BASED ON COMBI USE.
- EMA - EASY MAINTENANCE ACCESS. EASY ACCESS FOR MAINTENANCE OF THE APPLIANCE FROM THE BOTTOM FRONT PART AND RIGHT-HAND SIDE.
- 7 AUTOMATIC WASHING PROGRAMMES WITHOUT THE NEED FOR OPERATOR INPUT AFTER START-UP: MANUAL - RINSE - FAST - SOFT - MEDIUM ECO - HARD ECO - GRILL.
- "FAST" ULTRA-FAST WASHING IN 10'. MINIMUM INTERRUPTIONS TO THE WORK CYCLE AND CONSISTENTLY OPTIMAL CLEANING.
- MANUAL CLEANING SYSTEM WITH RETRACTABLE HAND-HELD SHOWER.
- EASY EXTERNAL CLEANING THANKS TO PERFECTLY SMOOTH SURFACES IN STAINLESS STEEL AND GLASS AND IPX5 PROTECTION AGAINST WATER SPLASHES.

INSTALLATION & ENVIRONMENT

- 100% RECYCLABLE PACKAGING.
- LCP - LIFE CYCLE PERSPECTIVE: CO2 CONSUMPTION - 380KGCO2 EQ/YEAR. THE CALCULATION WAS PERFORMED TAKING MOD. E101B (MODEL WITH STEAM GENERATOR), TAKING INTO ACCOUNT A HYPOTHETICAL RESTAURANT USE AND CONSIDERING 8 HOURS A DAY FOR 3.5 DAYS A WEEK, FORTY-EIGHT DAY PER YEAR.
- PRODUCT RECYCLING RATE 90%.
- QUALITY ISO 9001 / SAFETY ISO 45001 / ENVIRONMENTAL ISO 14001 CERTIFICATION.
- IT IS RECOMMENDED TO HAVE THE EQUIPMENT INSTALLED BY LAINOX ACCREDITED SERVICE CENTERS.
- OPERATION WITHOUT ADDING THE WATER SOFTENER AND DESCALER .
- IT IS RECOMMENDED TO HAVE PERIODIC MAINTENANCE CARRIED OUT BY A LAINOX SERVICE CENTER IN ACCORDANCE WITH THE MANUFACTURER'S RECOMMENDATIONS AND AS STATED IN THE MAINTENANCE MANUAL AND WARRANTY.
- COMPLIES WITH ENERGY STAR PARAMETERS. PUBLICATION ON WWW.ENERGYSTAR.GOV

STANDARD EQUIPMENT

- AUTOMATIC CLEANING SYSTEM VCS - SUPPLIED WITH 1 LIQUID CLEANSER CARTRIDGE CDL05, 990 GR.
 - CALOUT DESCALING SYSTEM SUPPLIED WITH ANTI-SCALE PRODUCT
 - MULTIPOINT CORE PROBE Ø 3 MM. FIXED PROBE
 - BUILT-IN AND RETRACTABLE HAND SHOWER WITH TAP
 - USB CONNECTION
 - TROLLEY NKS201
 - 6 SPEED FAN
-

OPTIONAL - TO BE REQUESTED WHEN ORDERING OVEN

- **NPK:** CONFIGURATION FOR CONNECTION TO EXTRACTION HOOD
- **SSB154:** EXTRA CHARGE FOR TROLLEY NKS154 - PASTRY VERSION - 15 X EN (600 X 400) - ↓ 89
- **SSB201S:** EXTRA CHARGE FOR TROLLEY NKS201S - GASTRONOMY VERSION - 15 X 1/1 GN - ↓ 83
- **LLG:** LONG LIFE GASKET - AUTOMATIC TRACKED FRAME HOLD AND RELEASE
- **DSP:** DISPLAY-CONTROL PANEL PROTECTION
- **CAM201B:** FLUE WITH WIND PROTECTION DEVICE FOR GAS MODELS. MODELS WITH BOILER
- **CAV201B:** FLUE WITH WIND PROTECTION DEVICE FOR GAS MODELS - DIRECT STEAM MODELS

EXTRA ACCESSORIES THAT CAN BE INSTALLED FOLLOWING PURCHASE

- **KSC004R:** MULTIPOINT CORE PROBE Ø 3 MM.
 - **KSC180:** MULTIPOINT CORE PROBE FOR LARGE ITEMS Ø 3 MM, PIN LENGTH 180 MM.
 - **KSA001:** NEEDLE CORE PROBE Ø 1 MM.
 - **NFX02:** FAT FILTER - 2 PCS.
 - **NKS201:** TROLLEY WITH DRIP TRAY - MAXIMUM LOAD 90 KG - MAXIMUM LOAD PER TRAY 25 KG
 - **NKS201S:** TROLLEY WITH DRIP TRAY - MAXIMUM LOAD 90 KG - MAXIMUM LOAD PER TRAY 25 KG
 - **NKS154:** TROLLEYS WITH DRIP TRAY - PASTRY VERSION 600 X 400 - MAXIMUM LOAD 90 KG - MAXIMUM LOAD PER TRAY 15 KG
 - **RIC201:** STAINLESS STEEL RAMP FOR TROLLEY INSERTION, HELPS TO EVEN THE FLOORS UP TO 3% OF UNEVENNES
 - **BKC201:** EXTRACTION HOOD WITH AIR-COOLED CONDENSER. AVAILABLE ONLY FOR PREARRANGED OVENS
 - **CCE:** COLLECTOR FOR EXTERNAL CONNECTION - Ø 150 MM
 - **RTP20E:** REGENERATING CABINET
 - **CPD20:** DETERGENT CONTAINER - CAPACITY 2 TANKS OF 10 KG.
 - **SPDP:** DETERGENT CONTAINER - TO BE INSTALLED ON THE WALL - CAPACITY 1 TANK OF 10 KG.
-

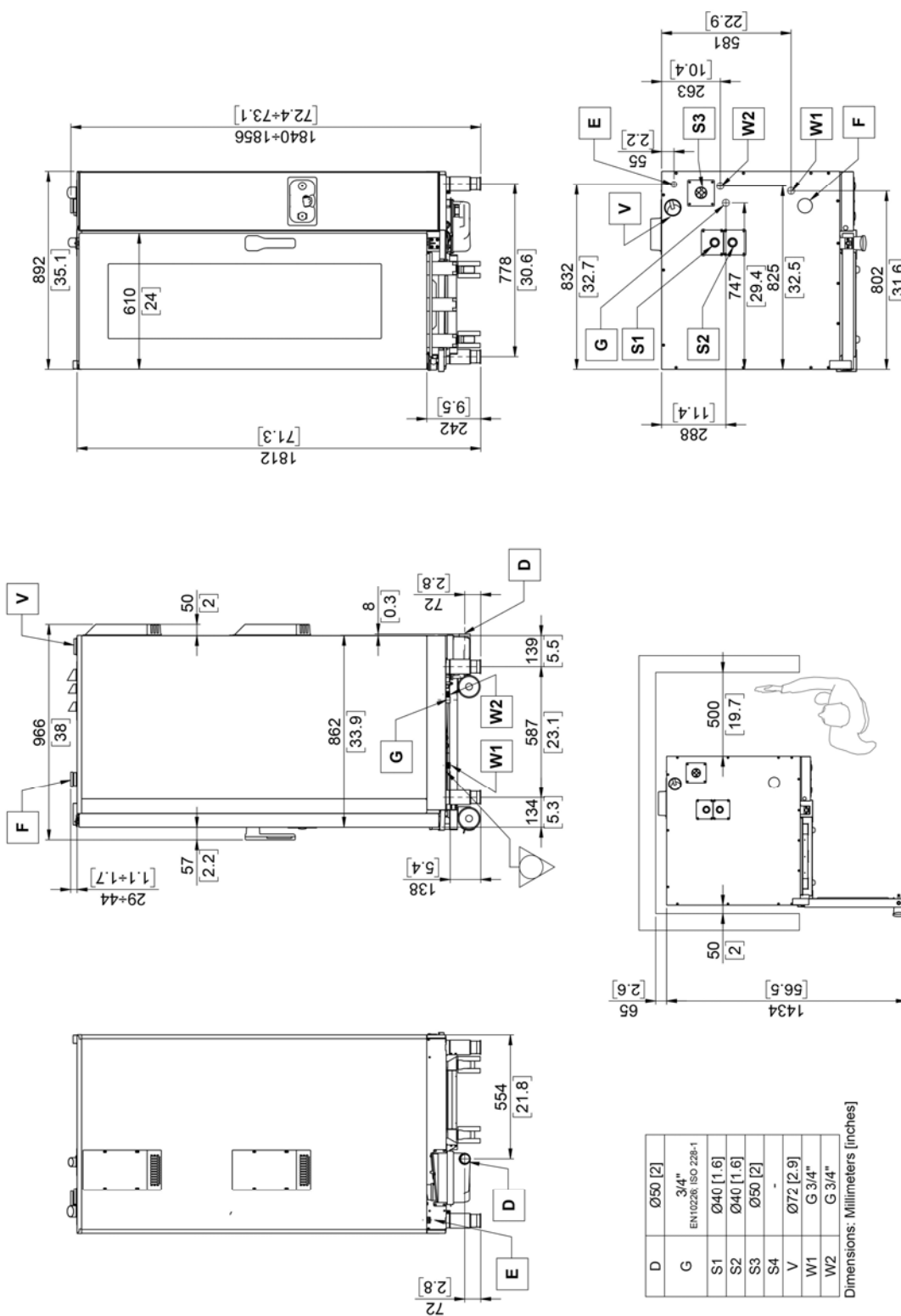

Component	Dimensions (mm)	Dimensions (inches)
A	Technical compartment cooling air intake	
D	Liquid discharge	
E	Electric power supply cable inlet	
F	Cooking chamber air intake	
G	Gas inlet	
S1	Cooking chamber fumes exhaust	
S2	Cooking chamber fumes exhaust	
S3*	Steam generator fumes exhaust	
S4*	Steam generator fumes exhaust	
V	Steam vent and cooking chamber pressure drop safety device	
W1	Water inlet	
W2	Softened water inlet	

* For model with steam generator

The data reported in this document is to be considered non-binding. The company reserves the right to make changes at any time, without prior notice. According to CE rules, gas ovens must be installed where proper evacuation of burnt gas can be provided (type B13, B23, A3)

