



## C6H/100S - Lincat Seal 650 Series Counter-top Curved Front Heated Merchandiser - Self- Service - W 1000 mm - 2.02 kW

Keep hot meats, pasties, pies and other foods at the perfect temperature with the Seal 650 Range Curved Front Heated Merchandiser.

- ✓ Elegant curved design with extruded aluminium frames and metallic silver finish enhances display without detracting from the contents
- ✓ Precise thermostatic control up to 95°C with digital display of cabinet temperature ensures food is maintained at a safe temperature
- ✓ Minimum food holding temperature of 72°C
- ✓ Humidity feature prevents food drying out - food stays in optimum condition for longer, reducing waste
- ✓ All-round visibility to maximise food sales potential
- ✓ Daylight-balanced illumination to enhance display of contents with easy change clip-in fluorescent light tubes

### Specifications

#### Summary

<b>Brand</b>	Lincat
<b>Range</b>	Seal
<b>Series</b>	650 Series
<b>Power Type</b>	Electric
<b>Unit Type</b>	Counter-top
<b>Available in UK Only</b>	No
<b>UK Warranty</b>	2 Years Parts and Labour Warranty
<b>Export Warranty</b>	Contact your local dealer
<b>GTIN</b>	5056105103844

#### Power and Performance

<b>Total Power kW</b>	2.02
<b>Temperature Range °C</b>	72-95
<b>IP Rating</b>	IP33
<b>Temperature Control</b>	Electronic

#### Key Specifications

<b>Number of Shelves included</b>	3
<b>Number of Shelf Positions</b>	3
<b>Service Type</b>	Self service
<b>Rack Type</b>	Static
<b>Type of Lighting</b>	Fluorescent
<b>Heated Base</b>	Yes

#### Weights and Dimensions

<b>Unit Height (External) mm</b>	755
<b>Unit Width (External) mm</b>	1000
<b>Unit Depth (External) mm</b>	650
<b>Shelf Dimensions Width mm</b>	900
<b>Shelf Dimensions Depth mm</b>	525
<b>Net Weight Kg</b>	67

#### Supply Connections

<b>Requires Installation</b>	No
<b>UK 3 Pin Plug</b>	Yes
<b>Requires Hardwiring</b>	No
<b>Electrical Supply Rating Watts</b>	2,020
<b>Single Phase Amps</b>	8.7
<b>Single Phase Voltage</b>	230

#### Shipping

<b>Packed Weight Kg</b>	73.7
<b>Packed Height cm</b>	90
<b>Packed Width cm</b>	115
<b>Packed Depth cm</b>	75

Technical Picture

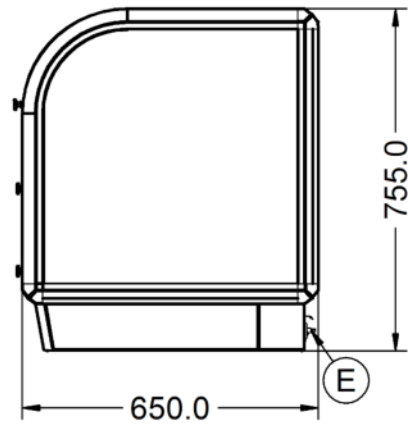
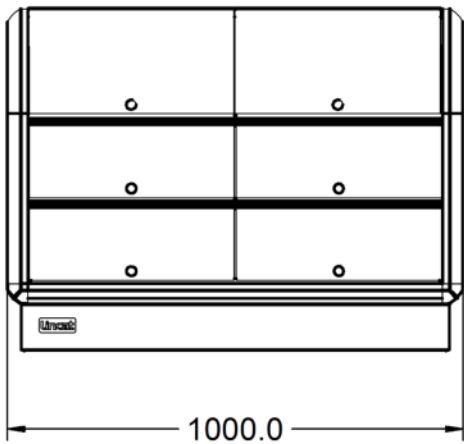
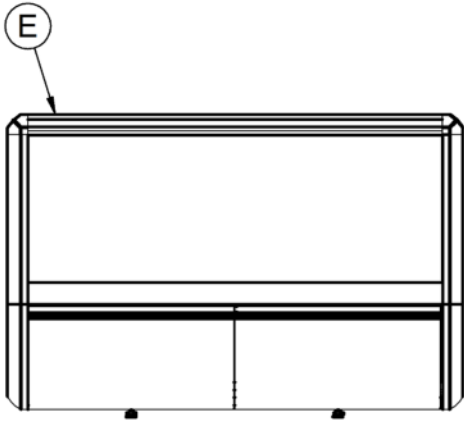

**Lincat Limited**

Whisby Road,  
Lincoln, LN6 3QZ,  
United Kingdom

**Company No:** 2175448

A member company of



**Customer Care**

**Tel:** +44 1522 875500  
**Email:** care@lincat.co.uk

**Export Customers**

**Tel:** +44 1522 875536  
**Email:** export@lincat.co.uk

**Opening Hours**

**Monday – Friday:**  
8.30am – 5pm