



DOMINATORPLUS

G3641 Smooth Griddle

Key features

- 18mm thick highly polished smooth steel griddle plate
 - Provides consistent, even heat
- Two independently-controlled burners
 - Vary the temperature across the surface if desired
- Temperature range of 140 - 300°C
 - Ideal for a wide range of food items
- Thermostatically controlled
 - Reduces energy consumption, improved operation
- Full height stainless steel surround
 - Ensures adjacent equipment remains spatter free
- Grease collection tray at front of unit
 - Catches and contains grease and fat
- Piezo ignition
 - Efficient and simple operation
- Laser-etched control icons
 - Permanent, indelible markings

Accessories

- Fixed stand
- Factory fitted, adjustable castors
- Fixed installation kit



Similar Models

- G3441 smooth griddle
- G3941 smooth griddle
- E3441 electric smooth griddle
- E3481 electric smooth griddle

Smooth Griddle

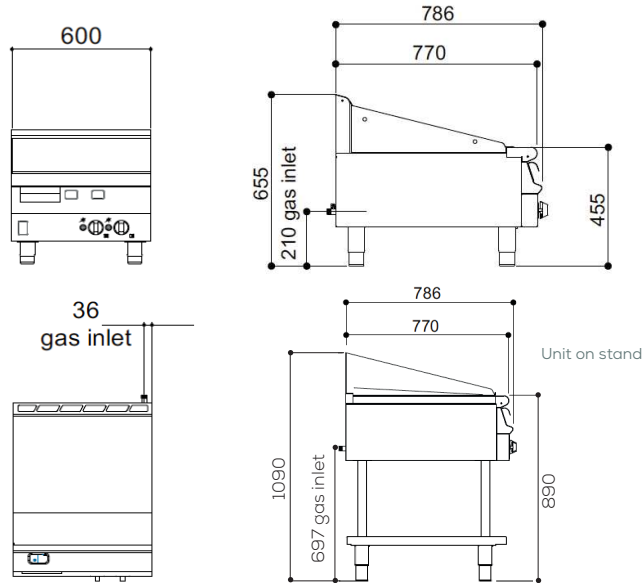

Measurements *in mm*

Unit on castors is the same hob height

Installation notes

Adequate ventilation must be provided to supply sufficient fresh air for combustion and to allow easy removal of any such products that may present a risk to health. Please consult current legislation for details that relate to specific locations.

Install unit on a level, fireproof surface in a well-lit, draught free position. If floor is made of a combustible material, local fire requirements must be checked to ensure compliance.

A clearance of 150mm should be observed between appliance and any combustible wall.

Specification details

Total rating (natural and propane - kW - Nett)	10.6	
Total rating (natural and propane - btu/hr - gross)	39,800	
Inlet size (natural and propane)	1/2" BSP	
Flow rate - natural (m ³ /hr)	1.16	
Flow rate - propane (kg/hr)	0.85	
Inlet pressure (natural and propane - mbar)	20 / 37	
Operating pressure (natural and propane - mbar)	15 / 37	
Burner rating (natural and propane - kW - Nett)	5.3	
Burner rating (natural and propane - btu/hr - gross)	19,900	
Number of burners	2	
Cooking area (w x d - mm)	595 x 485	
Weight (kg)	90	
Weight on stand (kg)	93	
Packed weight (kg)	75	
Packed dimensions (w x d x h - mm)	650 x 1000 x 650	
GTIN numbers	Nat Gas	LPG

