



DOMINATOR PLUS

E3840X Single Pan, Twin Basket Fryer

Key features

- Stainless steel hob with mild steel pan
 - Robust construction to withstand busy demands
- Temperature range between 130 - 190°C
 - Variable, precise control
- Sediment collection zone
 - Keeps oil cleaner for longer
- Resting position for elements
 - Allows easier, safe cleaning
- Fast-acting safety thermostat
 - Power cut to unit if oil overheats
- Drain bucket supplied as standard
 - Mounted upon slide for easy withdrawal
- Large diameter drain valve
 - Simple and efficient pan draining
- Supplied with fish grid, basket and lid
 - Everything you need to start frying

Accessories

- Sidescreens
- Factory fitted, adjustable castors
- Fixed installation kit

Similar Models

- E3840F Single pan, twin basket fryer with filtration
- E3860 Single pan, twin basket fryer
- G3840 Single pan, twin basket gas fryer



FRYER ANGEL

The unique *Falcon Fryer Angel* safety system prevents fryer fires, making it a must-have for any commercial kitchen.

The most common causes of fryer fire occur when oil levels are too low during cooking or when the appliance is switched on without the operator checking to see if there is enough oil in the pan. The *Falcon Fryer Angel* eradicates this by simply cutting power to the unit if the oil level is not at a sufficiently high level.

The Falcon Fryer Angel - making your kitchen safer!

Patent applied for, Patent Application No. 2002725.6 (UK), PCT/GB2020/050462 (International)

Single Pan, Twin Basket Fryer

Measurements *in mm*

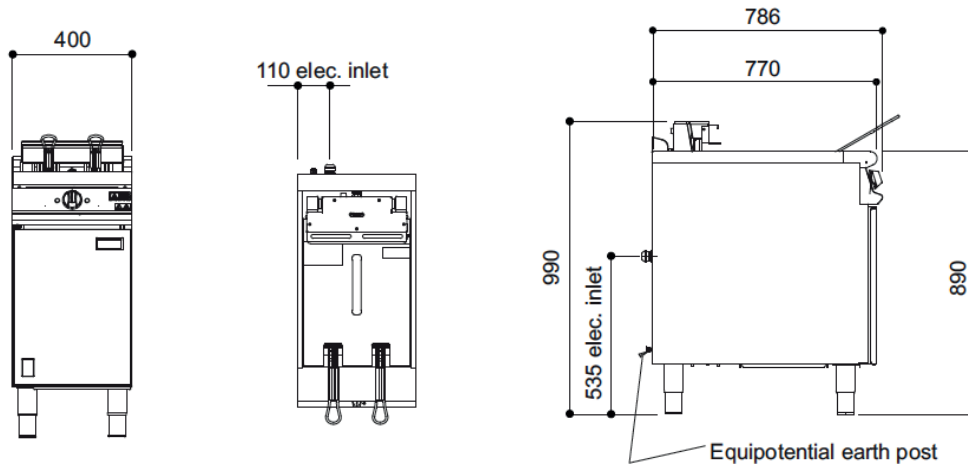

Unit on castors is the same hob height

Specification *details*

| | | |
|-------------------------------------|----------------------|---------------|
| Electrical rating (kW) | 20 | |
| Electrical supply voltage | 400V 3N~ | |
| Required electrical supply 400V (A) | 32 | |
| Electrical current split (A) | L1: 29 L2: 29 L3: 29 | |
| Oil capacity (litres) | 20 | |
| Hourly chip output (kg) | 58 | |
| Weight (kg) | 66 | |
| Packed weight (kg) | 75 | |
| Packed dimensions (w x d x h - mm) | 450 x 1000 x 1100 | |
| GTIN numbers | On feet | On castors |
| | 5056466906986 | 5056466907167 |

Installation notes

Adequate ventilation must be provided to supply sufficient fresh air and to allow easy removal of any such products that may present a risk to health. Please consult current legislation for details that relate to specific locations.

Install unit on a level, fireproof surface in a well-lit position. If floor is made of a combustible material, local fire requirements must be checked to ensure compliance.

A clearance of 150mm should be observed between appliance and any combustible wall.

