



## **DOMINATOR***PLUS*

# *E3625 Electric Chargrill*

### Key features

- Element heats up very quickly
  - Switch on as and when required, saving energy
- Cook directly on element
  - Delivers branding marks expected of chargrilling
  - Provides even cooking across the entire cooking area
- Removable grease container needs no water
  - No having to separate grease and water for disposal
- Magnetic sidescreens can be removed
  - Easy to clean
- Upward swivel element
  - Makes it much easier and safer to clean
- Laser-etched control icons
  - Permanent, indelible markings

### Accessories

- Fixed stand
- Factory fitted, adjustable castors
- Easy-clean lining sheet
- High capacity grease collection system
- Fixed installation kit

### Similar Models

- E3925 Electric chargrill
- E9460 Electric chargrill
- E9490 Electric chargrill



## Electric Chargrill

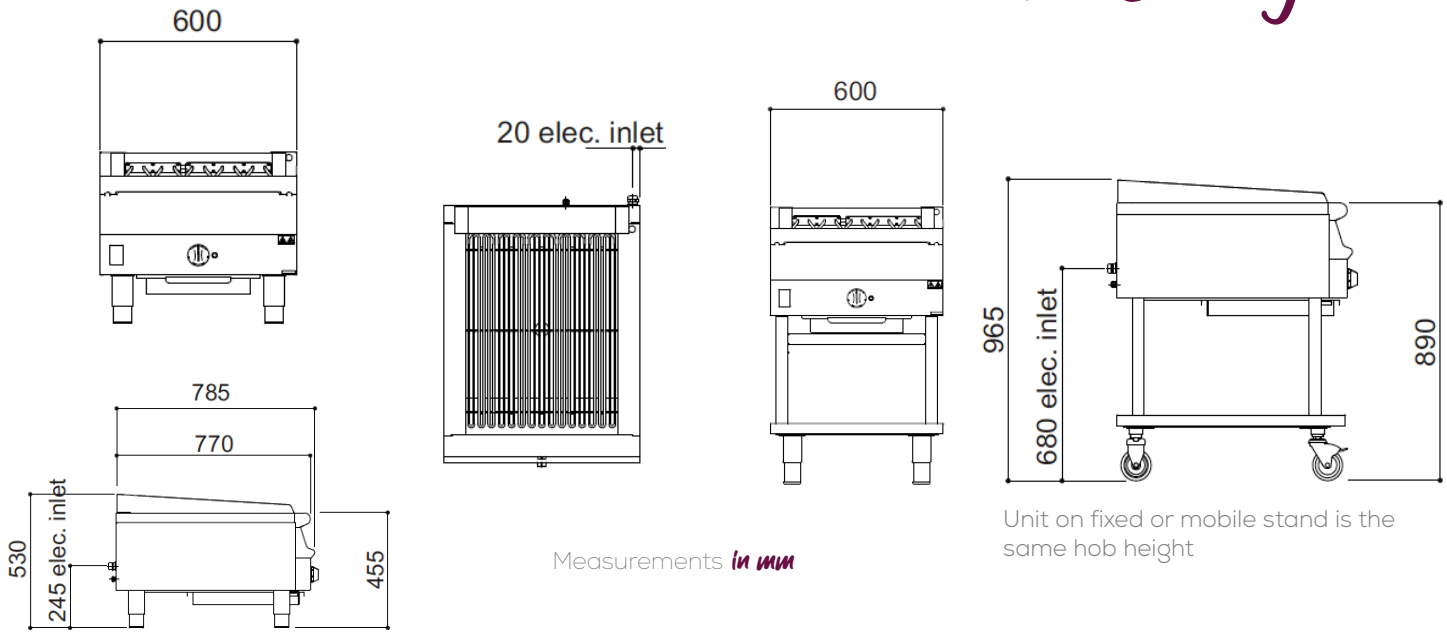

### Specification details

Electrical rating (kW)	8.4
Electrical supply voltage	400V 3N~
Required electrical supply (A)	32
Electrical current split (A)	L1: 11 L2: 15 L3: 11
Weight (kg)	47
Weight on stand (kg)	68
Packed weight (kg)	57
Packed dimensions (w x d x h - mm)	650 x 1000 x 700
GTIN number	

### Installation notes

Adequate ventilation must be provided to supply sufficient fresh air for combustion and to allow easy removal of any such products that may present a risk to health. Please consult current legislation for details that relate to specific locations.

Install unit on a level, fireproof surface in a well-lit, draught free position. If floor is made of a combustible material, local fire requirements must be checked to ensure compliance.

A clearance of 150mm should be observed between appliance and any combustible wall.

