



DOMINATOR*PLUS*

E3512 Grill

Key features

- Single element controlled by energy regulator
 - Easy to adjust cooking temperature
- Double-cased with internal insulation
 - Provides optimal heat retention
- Supplied with reversible brander
 - Increases cooking versatility
- Five position shelf runners
 - Provides flexible cooking options
- Gastronorm compatible
 - Takes 1/1 GN tray so ideal for bulk cooking
- Oil collection tray mounted on grid shelf
 - Catches any liquid grese during grilling
- Removable drip tray
 - Catches grease and debris during grilling
- All stainless steel exterior, cast iron chamber linings
 - Easy to clean, long lasting and robust

Accessories

- Brander
- Brander carrier
- Floor stand
- Wall bracket
- Bench Legs

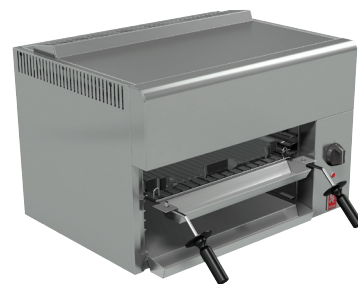

Similar Models

- E3532 electric grill
- G3512 gas grill
- G3532 gas grill

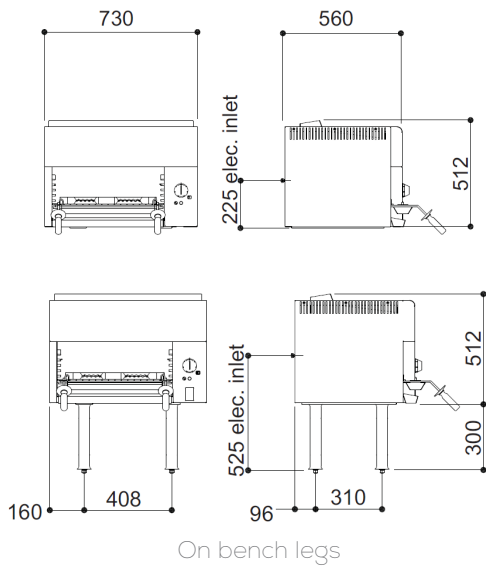

Measurements *in mm*

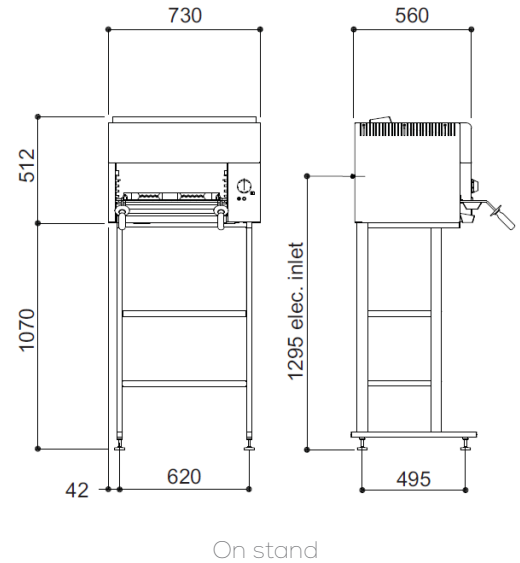
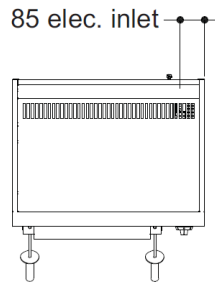

Specification details

Electrical rating (kW)	5.2
Electrical supply voltage	230V N~
Amps per phase (A)	L1: 22.5
Gastronorm compatibility	1/1
Weight (kg)	57
Packed weight (kg)	67
Packed dimensions (w x d x h - mm)	800 x 600 x 700
GTIN number	

Installation notes

Adequate ventilation must be provided to supply sufficient fresh air and to allow easy removal of any such products that may present a risk to health. Please consult current legislation for details that relate to specific locations.

A clearance of 150mm should be observed between appliance and any combustible wall.

