



DOMINATORPLUS

E3481R Half-Ribbed Griddle

Key features

- 18mm highly polished half-ribbed steel griddle plate
 - Provides consistent, even heat
- Temperature range of 80 - 290°C
 - Ability to prepare a wide range of foods
- Thermostatically-controlled
 - Reduces energy consumption, improved operation
- Removable grease container
 - Retains grease for quick and easy cleaning
- Full height surround
 - Protects surrounding areas from splatter
- Laser-etched control icons
 - Permanent, indelible markings

Accessories

- Fixed stand
- Factory fitted, adjustable castors
- Fixed installation kit



Similar Models

- E3481 Smooth griddle
- E3441R Half-ribbed griddle
- E3441 Smooth griddle
- G3641R Ribbed gas griddle
- G3641 Smooth gas griddle

Half-Ribbed Griddle

Measurements *in mm*

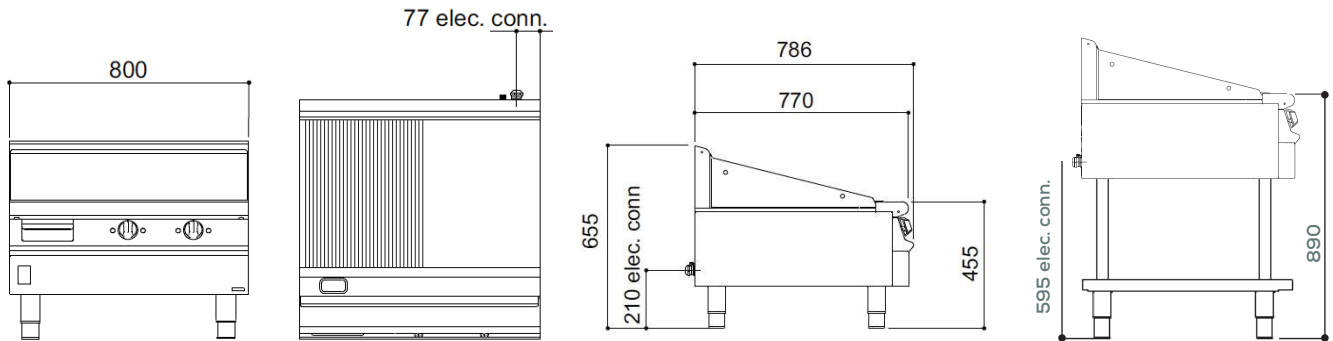

Unit is the same hob height on fixed or mobile stand

Specification *details*

Electrical rating (kW)	6.88
Electrical supply voltage	400V 2N~
Required electrical supply 400V 2N~ (A)	20
Electrical current split (A)	L1: 14.97 L2: 14.97
Weight (kg)	98
Weight on stand (kg)	128
Packed weight (kg)	111
Packed dimensions (w x d x h - mm)	850 x 1000 x 900
GTIN number	

Installation notes

Adequate ventilation must be provided to supply sufficient fresh air for combustion and to allow easy removal of any such products that may present a risk to health. Please consult current legislation for details that relate to specific locations.

Install unit on a level, fireproof surface in a well-lit, draught free position. If floor is made of a combustible material, local fire requirements must be checked to ensure compliance.

A clearance of 150mm should be observed between appliance and any combustible wall.

