



## OE8016 - Lincat Opus 800 Electric Free-standing Oven Range - W 900 mm - 21.6 kW

The Opus 800 Electric range 6 plate is designed to deliver fast responsive heat via its Powerful heavy-duty cast iron round hot plates.

- ✔ Powerful heavy-duty cast iron 2.6kW round hot plates deliver fast responsive heat
- ✔ Fully pressed sealed hob for easy cleaning
- ✔ Large 6 x GN1/1 capacity oven enabling six different foods to be cooked simultaneously
- ✔ Electric Oven Ranges

### Specifications

#### Summary

<b>Brand</b>	Lincat
<b>Range</b>	Opus 800
<b>Power Type</b>	Electric
<b>Unit Type</b>	Free-standing
<b>Available in UK Only</b>	No
<b>UK Warranty</b>	2 Years Parts and Labour Warranty
<b>Export Warranty</b>	Contact your local dealer
<b>GTIN</b>	5056105102410

#### Power and Performance

<b>Total Power kW</b>	21.6
<b>Temperature Range °C</b>	130-250
<b>IP Rating</b>	IP24
<b>Cooking Area (Width x Depth) mm</b>	6 x 214 dia.
<b>Temperature Control</b>	Mechanical
<b>Rating per Hob kW</b>	2.6
<b>Oven Rating kW</b>	6.0

#### Key Specifications

<b>Number of Shelves included</b>	2
<b>Number of Shelf Positions</b>	5
<b>Number of Hobs</b>	6
<b>Shape of Hob</b>	Round

#### Capacity

<b>Gastronorm Capacity</b>	6 x GN1/1
----------------------------	-----------

#### Weights and Dimensions

<b>Unit Height (External) mm</b>	925
<b>Unit Width (External) mm</b>	900
<b>Unit Depth (External) mm</b>	800
<b>Height (Internal) mm</b>	405
<b>Width (Internal) mm</b>	715
<b>Depth (Internal) mm</b>	512
<b>Shelf Dimensions Width mm</b>	710
<b>Shelf Dimensions Depth mm</b>	512
<b>Hob Dimensions mm</b>	235
<b>Net Weight Kg</b>	129.4

#### Supply Connections

<b>Requires Installation</b>	Yes
<b>Requires Electrical Supply</b>	Yes
<b>UK 3 Pin Plug</b>	No
<b>Requires Hardwiring</b>	Yes
<b>Electrical Supply Rating Watts</b>	21,600
<b>Three Phase Amps</b>	L1=31.3; L2=31.3; L3=31.3
<b>Three Phase Voltage</b>	400

#### Shipping

<b>Packed Weight Kg</b>	147.4
<b>Packed Height cm</b>	102
<b>Packed Width cm</b>	100
<b>Packed Depth cm</b>	85

### Available Accessories

<b>LK12</b>	NULL
<b>OA8982</b>	SPLASHBACK/SHELF - OE8008 & OE8016

Technical Picture

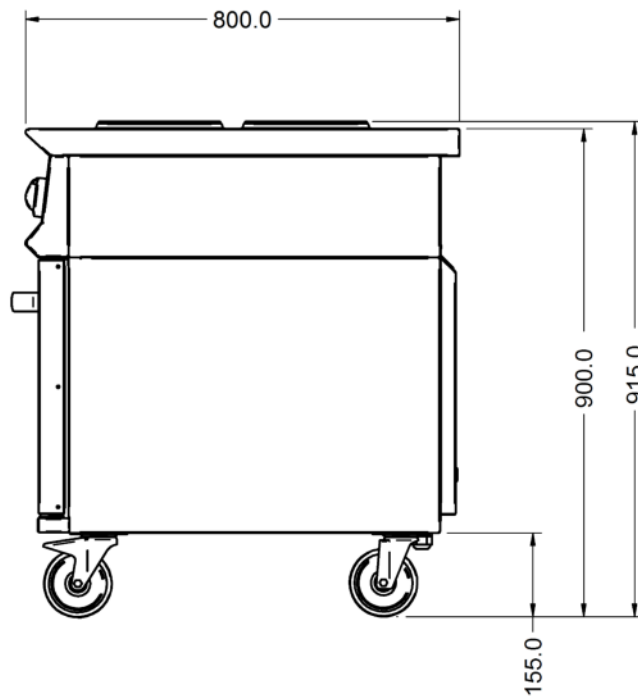
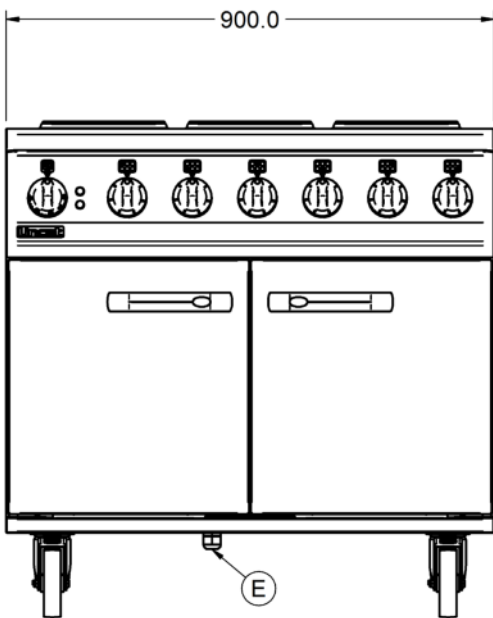
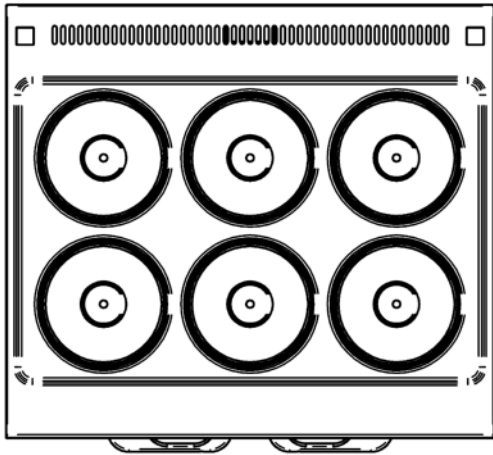

**Lincat Limited**

Whisby Road,  
Lincoln, LN6 3QZ,  
United Kingdom

**Company No:** 2175448

A member company of



**Customer Care**

**Tel:** +44 1522 875500  
**Email:** care@lincat.co.uk

**Export Customers**

**Tel:** +44 1522 875536  
**Email:** export@lincat.co.uk

**Opening Hours**

**Monday – Friday:**  
8.30am – 5pm