



LC110B/N - Lincat Visual Cooking 1.10 Natural Gas Counter-top Combi Oven - Boiler - W 897 mm - 21.0 kW [Gas] + 1.0 kW [Electric]

Choose Visual Cooking where high output and precise control are required.

- ✓ Intuitive touch display SmartTouch® for programming
- ✓ Efficient, controlled production and injection of steam, with hybrid boiler and injection steam production
- ✓ CombiSmart® 10-step humidity control, and ClimaOptima® automatic humidity control functions
- ✓ Ability to create cooking programmes with up to 15 steps
- ✓ Rack timer allowing accurate cooking times for different items on different shelves
- ✓ 10 x GN1/1 capacity
- ✓ Ideal for menus which require a high volume of steaming
- ✓ Two-step safety handle

Specifications

Summary		Power and Performance	
Brand	Lincat	BTU per Hour	80,000
Range	Lincat Combi Ovens	Total Power kW	1
Series	Visual Cooking	Temperature Range °C	30-300
Power Type	Gas	IP Rating	IPX5
Gas Type	Natural Gas	Temperature Control	Electronic
Unit Type	Counter-top	Oven Rating kW	Steam connection = 21.0; Hot air connection = 21.0
Available in UK Only	Yes		
UK Warranty	2 Years Parts and Labour Warranty		
GTIN	5056105120292		

Key Specifications		Capacity	
WRAS Approved	Yes	Gastronorm Capacity	10 x GN1/1
Type of Lighting	Halogen	Portions per Day	150
Number of Grids included	0		

Weights and Dimensions		Supply Connections	
Unit Height (External) mm	1075	Requires Installation	Yes
Unit Width (External) mm	897	Requires Electrical Supply	Yes
Unit Depth (External) mm	831	UK 3 Pin Plug	Yes
Height (Internal) mm	785	Requires Hardwiring	No
Width (Internal) mm	460	Electrical Supply Rating Watts	1,000
Depth (Internal) mm	690	Single Phase Amps	8.5
Net Weight Kg	175	Single Phase Voltage	230
		Gas Connection BSP	3/4"
		Gas Pressure Natural mbar	18-25
		Total heat input at full rate Natural kW	21
		Total heat input at full rate Natural BTU per hour	80,000
		Water Connection Pressure Bar	2.5-6
		Drain Connection	DN 50 mm
		Water Connection	3/4"

Shipping

Packed Weight Kg	195
Packed Height cm	121
Packed Width cm	100
Packed Depth cm	120

Available Options

INSTALLATION

LCO2001 Site Survey & Installation

COMMISSIONING

LCO3001 Commissioning

R/H DOOR INSTALL

LCO2002 Right Hinged Door Installation

Available Accessories

LCA1006L	Lincat Combi Oven CombiPlus Stacking Kit and Low Floor Stand - for Visual Cooking 1.06 on 1.10 Gas - Boiler - Left Hinged Model
LCA1006R	Lincat Combi Oven CombiPlus Stacking Kit and Low Floor Stand - for Visual Cooking 1.06 on 1.10 Gas - Boiler - Right Hinged Model
LCA3003	Lincat Combi Oven Imperial Non-stick Container - GN1/1(325 x 530 mm) - 20 mm deep
LCA3005	Lincat Combi Oven Imperial Non-stick Container - GN1/1(325 x 530 mm) - 40 mm deep
LCA3007	Lincat Combi Oven Imperial Non-stick Container - GN1/1(325 x 530 mm) - 60 mm deep
LCA3009	Lincat Combi Oven Imperial Pizza and Grilling Sheet - GN1/1(325 x 530 mm)
LCA3011	Lincat Combi Oven Imperial Grilling Grid - GN1/1(325 x 530 mm)
LCA3012	Lincat Combi Oven Imperial Potato Grid - GN1/1(325 x 530 mm) - 28 Potato Capacity
LCA3013	Lincat Combi Oven Imperial Multi-tray - 8 Moulds - GN1/1(325 x 530 mm)
LCA3015	Lincat Combi Oven Non-stick Aluminium Baking Sheet - GN1/1(325 x 530 mm)
LCA3017	Lincat Combi Oven Non-stick Perforated Aluminium Baking Sheet - GN1/1(325 x 530 mm)
LCA3019	Lincat Combi Oven Silicone Baking Mat - GN1/1(325 x 530 mm)
LCA3021	Lincat Combi Oven Steamfry Basket - GN1/1(325 x 530 mm)
LCA3023	Lincat Combi Oven Rack for Spare Ribs - GN1/1(325 x 530 mm)
LCA3024	Lincat Combi Oven Chicken Grid - GN1/2(325 x 265 mm) - 4 Chicken Capacity
LCA3025	Lincat Combi Oven Chicken Grid - GN1/1(325 x 530 mm) - 8 Chicken Capacity
LCA4001	Lincat Combi Oven Software Key - Quick Select Recipes (QSR)
LCA4002	Lincat Combi Oven Software Key - Advanced Rack Timer - Tailored Menu Handling
LCA5001	Lincat Combi Oven Condenser Hood - for Visual Cooking 1.06/1.10/1.20 not Stacked Units
LCA6002	Lincat Combi Oven Static Stand for Visual Cooking 1.06/1.10 - 8 Pairs of Support Rails
LCA6004	Lincat Combi Oven Mobile Stand for Visual Cooking 1.06/1.10 - 8 Pairs of Support Rails
LCC1001	Hydro Shield 3600(L) Water Filter Cartridge - Recommended for CombiSlim and Visual Cooking 1.06/1.10
LCC1002	Hydro Shield 6000(XL) Water Filter Cartridge - Recommended for Visual Cooking 1.20/2.06/2.10/2.20 and all Combi Ovens in hard water areas
LCC1003	Hydro Shield 3600(L) Water Filter Kit - Including Filter, Filter Head and Hose - Recommended for CombiSlim and Visual Cooking 1.06/1.10
LCC1004	Hydro Shield 6000(XL) Water Filter Kit - Including Filter, Filter Head and Hose - Recommended for 1.20/2.06/2.10/2.20 + all Ovens in hard water areas
LCC2003	Lincat Protect Intense Detergent - 2 x 5l
LCC2005	Lincat Protect Cleaning Package - 6 x 5l Intense Detergent and 2 x 5l Rinse Aid
LCC2006	Lincat Protect Rinse Aid - 2 x 5l

Technical Picture

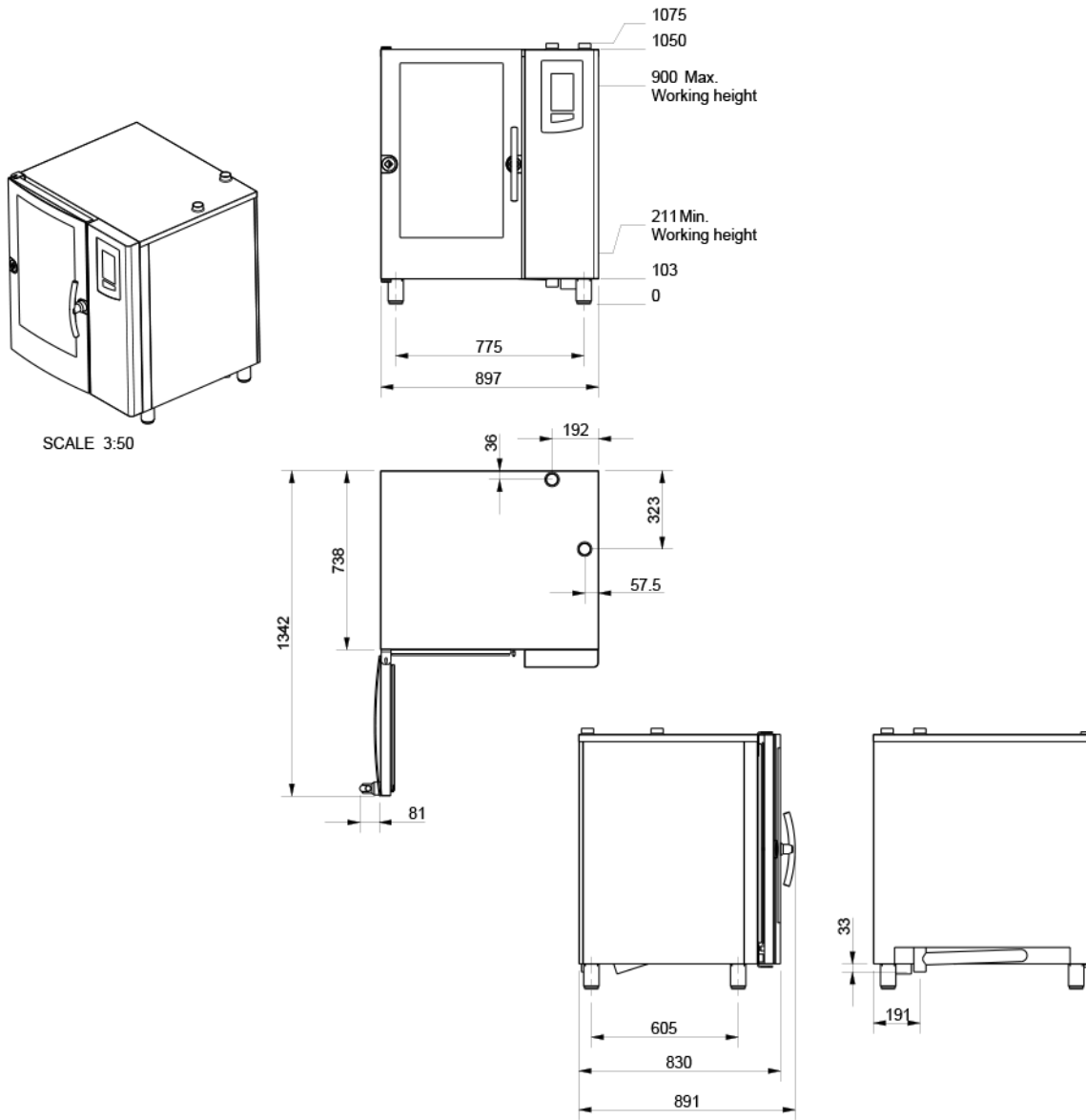

Lincat Limited

Whisby Road,
Lincoln, LN6 3QZ,
United Kingdom

Company No: 2175448

A member company of



Customer Care

Tel: +44 1522 875500
Email: care@lincat.co.uk

Export Customers

Tel: +44 1522 875536
Email: export@lincat.co.uk

Opening Hours

Monday – Friday:
8.30am – 5pm