

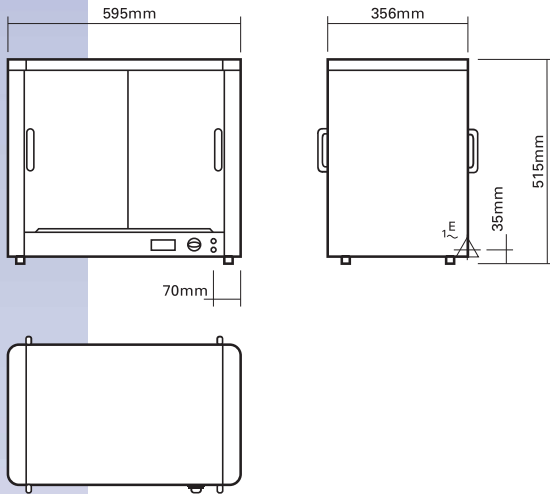

E83 & E84 FOOD WARMERS

- Thermostat control
- Temperature display
- Stay-cool door handles
- Easy-clean removable glass doors
- Anti-pilfer door locking clip
- Solid glass back option (no extra cost)
- Plugs into 10A power supply

E83 Food Warmer



E84 Food Warmer

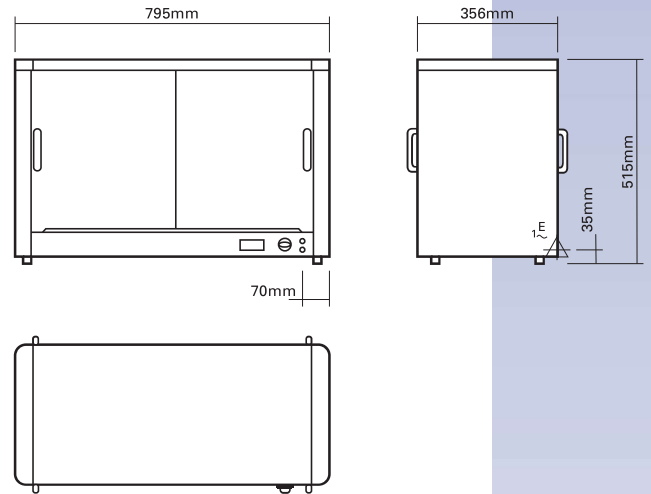

SPECIFICATIONS

Capacity	E83 50 pies
	E84 80 – 100 pies
Rack sizes	E83 4 racks, 493 x 295mm
	E84 4 racks, 693 x 295mm
Power Supply	E83 220-240V 800W 3.4A
	E84 220-240V 1100W 4.6A
Shipping Data	E83 19.5kg, 0.16m ³ packed
	E84 25kg, 0.21m ³ packed



The cabinet temperature is accurately controlled by thermostat and the handy addition of a temperature display conforms to current health and hygiene requirements.



ISO9001

All Blue Seal products are designed and manufactured by Moffat using the internationally recognised ISO9001 quality management system, covering design, manufacture and final inspection, ensuring consistent high quality at all times.

Ask for brochures for all Blue Seal models from your nearest distributor



www.blue-seal.co.uk

United Kingdom
Blue Seal Limited
 Units 6-7 Mount St
 Business Park
 Birmingham B7 5QU
 England
 Ph 0121-327 5575
 Fax 0121-327 9711
 Email sales@blue-seal.co.uk
www.blue-seal.co.uk

Australia
Moffat Pty Limited
 740 Springvale Rd
 Mulgrave
 Victoria 3170
 Australia
 Ph 03-9518 3888
 Fax 03-9518 3833
 Email vsales@moffat.com.au
www.moffat.com.au

New Zealand
Moffat Limited
 16 Osborne St
 PO Box 10-001
 Christchurch
 New Zealand
 Ph 03-389 1007
 Fax 03-389 1276
 Email sales@moffat.co.nz
www.moffat.co.nz

U.S.A
Moffat Inc
 3765 Champion Boulevard
 Winston-Salem
 North Carolina 27105
 Call Free 1800 551 8795
 Ph 336-661 0257
 Fax 336-661 9546
 Email sales@moffat.com
www.moffat.com