



DOMINATOR*PLUS*

E3122 Two Hotplate Boiling Top

Key features

- Features two fast-heating circular hotplates
 - Rapid heat up times
- Plunged hob contains spillages
 - Easy and quick to clean
- Variable, accurate temperature control
 - Ideal for a wide range of menu items
- Laser-etched control icons
 - Permanent, indelible markings

Accessories

- Fixed stand
- Factory fitted, adjustable castors
- Fixed installation kit



Similar Models

- E3121 3HP boiling top
- E3121 3HP boiling top
- E9042 2HP boiling top

Two Hotplate Boiling Top

Measurements *in mm*

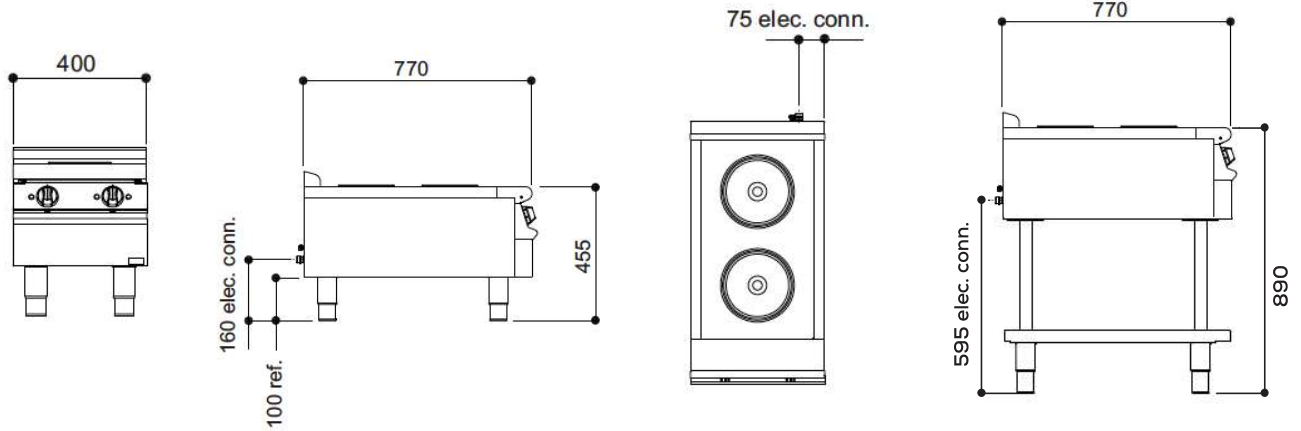

Unit on castors is the same hob height

Specification *details*

Electrical rating (kW)	4
Electrical supply voltage	230V~
Minimum electrical supply 230V~ (A)	16
Electrical current split (A)	L1: 16
Hotplate rating (kW)	2 x 2
Weight (kg)	25
Weight on stand (kg)	43
Packed weight (kg)	33
Packed dimensions (w x d x h - mm)	450 x 1000 x 600
GTIN number	

Installation notes

Adequate ventilation must be provided to supply sufficient fresh air and to allow easy removal of any such products that may present a risk to health. Please consult current legislation for details that relate to specific locations.

Install unit on a level, fireproof surface in a well-lit position. If floor is made of a combustible material, local fire requirements must be checked to ensure compliance.

A clearance of 150mm should be observed between appliance and any combustible wall.

