

ELECTRIC CHIP SCUTTLE 450mm

CS45E

OVERALL CONSTRUCTION

- Stainless steel drain screen
- Stainless steel pan
- Bull nose welded 1.5mm stainless steel
- Splashback and side panels 1.2mm stainless steel

CONTROLS

- On / Off power / heater switch

CLEANING AND SERVICING

- Easy clean stainless steel exterior
- Lift out drain screen
- All service access from front of unit



- Heavy-duty construction
 - Easy clean stainless steel pan
 - 1.0kW infrared ceramic heater
 - Removable scoop / drain screen
 - Stainless steel exterior
 - Black vitreous enamel finish to front panels
 - Easy service
 - Fully modular
-

ELECTRIC CHIP SCUTTLE 450mm

CS45E

CS45E

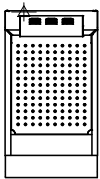
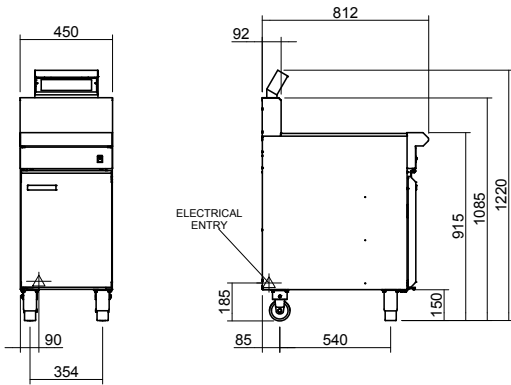

SPECIFICATIONS

Heating Element

1 x 1kW ceramic infrared heater

Electrical requirements

1kW, 220-240Vac, 50/60hz,

1P+N+E 4.5A

3 pin 10A cordset fitted

Electrical connection

90mm from RH side

200mm from floor

Dimensions

Width 450mm

Depth 805mm

Height 915mm

Incl. heater 1224mm

Nett weight

53kg

Packing data

0.58m³, 95kg

Width 490mm

Depth 865mm

Height 1350mm

OPTIONS AT EXTRA COST

Joining caps

Side splash guards

Castors

Plinth mounting



www.blue-seal.co.uk

United Kingdom

blue-seal.co.uk

Blue Seal Limited

Unit 67

Gravelly Business Park

Gravelly

Birmingham B24 8TQ

England

Telephone 0121-327 5575

Facsimile 0121-327 9711

sales@blue-seal.co.uk

Australia

moffat.com.au

Moffat Pty Limited

740 Springvale Road

Mulgrave

Victoria 3170

Australia

Telephone +613-9518 3888

Facsimile +613-9518 3833

vsales@moffat.com.au

New Zealand

moffat.co.nz

Moffat Limited

45 Illinois Drive

Izone Business Hub

Rolleston 7675

New Zealand

Telephone +64 3-983 6600

Facsimile +64 3-983 6660

sales@moffat.co.nz

International

moffat.com

international@moffat.co.nz



Designed and manufactured by



ISO9001

All Blue Seal products are designed and manufactured by Moffat using the internationally recognised ISO9001 quality management system, covering design, manufacture and final inspection, ensuring consistent high quality at all times.

In line with policy to continually develop and improve its products, Moffat Limited reserves the right to change specifications and design without notice.



Copyright Moffat Ltd.
UK.BS.2017

an Ali Group Company



The Spirit of Excellence