

Model: A15C Coldkit Araya A15C
 1.5 Metre, Curved Glass, Serve Over Counter

Technical Drawing

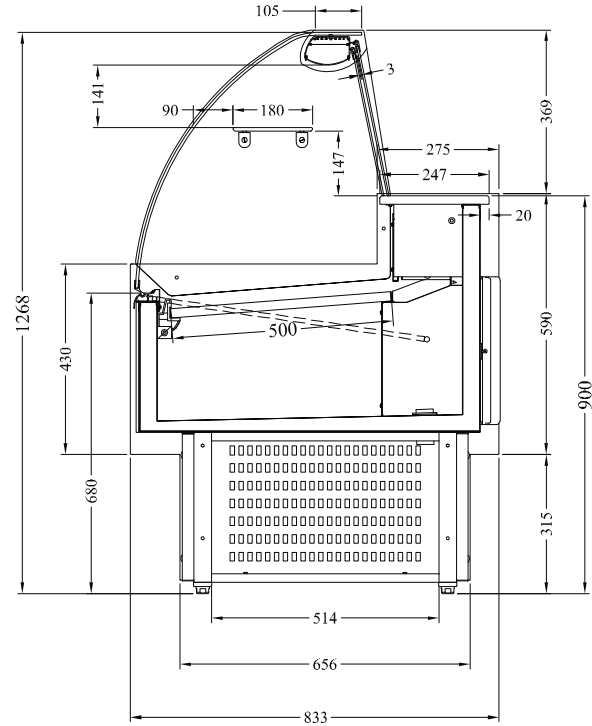
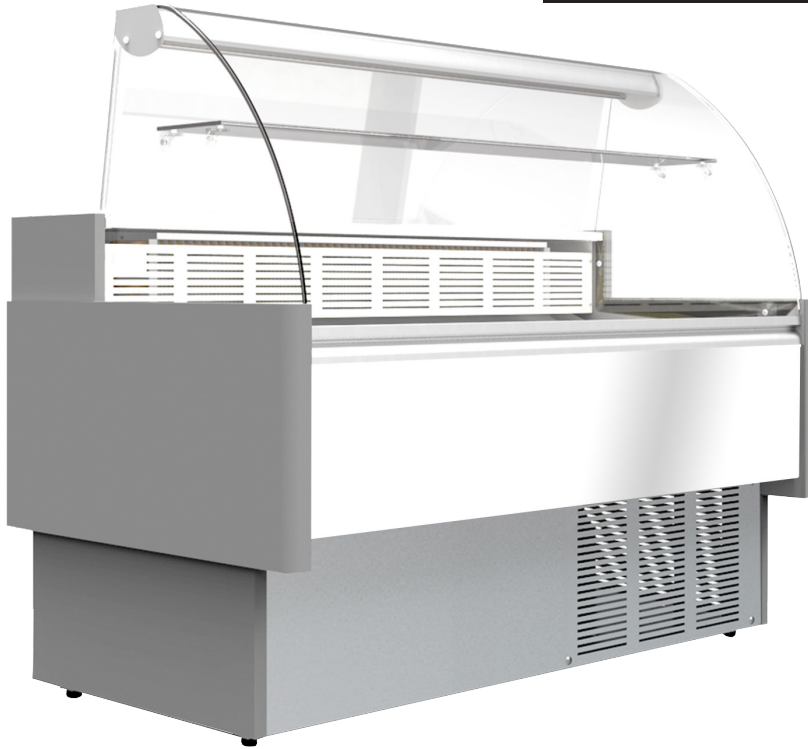

Key Features

Construction

Available Options

- +1°C to +10°C temperature range
- Digital temperature control
- Refrigerated under storage
- Ambient intermediate shelf
- Lightweight design, easy to install
- Digital temperature control
- Digital temperature display
- Illuminated display deck
- 500mm deep deck
- Switchable static or fan assisted cooling
- Fog resistant glass
- Suitable up to 30°C ambient
- R404a refrigerant

- Painted steel construction
- Curved glass design

- Any RAL colour front panel
- Perspex rear doors
- Stainless steel deck
- Step deck

Technical Data

Model	A15C
Capacity	249 Litres
Display Area	0.94m ²
Intermediate shelf dimensions	1402 x 180
External Dimensions	Width = 1500 Depth = 833 Height = 1268
Interior Finish	White
Exterior Finish	Grey / White
Rear Storage Doors	1
Internal Lighting	✓
Internal Lighting Type	Flourescent
Light switch	✓
Light switch position	Externally mounted
Temperature control	Digital
Temperature control position	External
Temperature range	+1° to +10°c
Refrigerant	R404a

Approvals

Available At

Document #

