



V6 - Lincat Silverlink 600 Electric Free-standing Oven - W 600 mm - 3.0 kW

The Silverlink 600 Electric Oven guarantees excellent performance and optimum efficiency.

- ✓ Excellent performance and optimum efficiency oven operating from a 13A plug
- ✓ Accommodates 2/3 gastronorms
- ✓ Four shelf positions with two removable shelves
- ✓ Able to support Silverlink 600 counter top units such as boiling tops, bains marie, griddles and work tops
- ✓ Stainless steel interior with radiused corners and removable side shelf supports for easy cleaning

Specifications

Summary

Brand	Lincat
Range	Silverlink 600
Power Type	Electric
Unit Type	Free-standing
Available in UK Only	No
UK Warranty	2 Years Parts and Labour Warranty
Export Warranty	Contact your local dealer
GTIN	5056105100188

Power and Performance

Total Power kW	3.00
Temperature Range °C	50-250
IP Rating	IP34
Temperature Control	Mechanical
Oven Rating kW	3.00

Key Specifications

Number of Shelves included	2
Number of Shelf Positions	4

Capacity

Gastronorm Capacity	1 x GN2/3
----------------------------	-----------

Weights and Dimensions

Unit Height (External) mm	674
Unit Width (External) mm	600
Unit Depth (External) mm	623
Height (Internal) mm	420
Width (Internal) mm	470
Depth (Internal) mm	335
Shelf Dimensions Width mm	455
Shelf Dimensions Depth mm	335
Net Weight Kg	45

Supply Connections

Requires Installation	No
Requires Electrical Supply	Yes
UK 3 Pin Plug	Yes
Requires Hardwiring	No
Electrical Supply Rating Watts	3,000
Single Phase Amps	13.0
Single Phase Voltage	230

Shipping

Packed Weight Kg	57.3
Packed Height cm	102.3
Packed Width cm	70.3
Packed Depth cm	70.3

Available Accessories

SLS6V	Lincat Silverlink 600 Free-standing Floor Stand - for V6 Series Ovens - W 600 mm
V6/T	V6 TOP COVER - ACCESSORY ONLY

Technical Picture

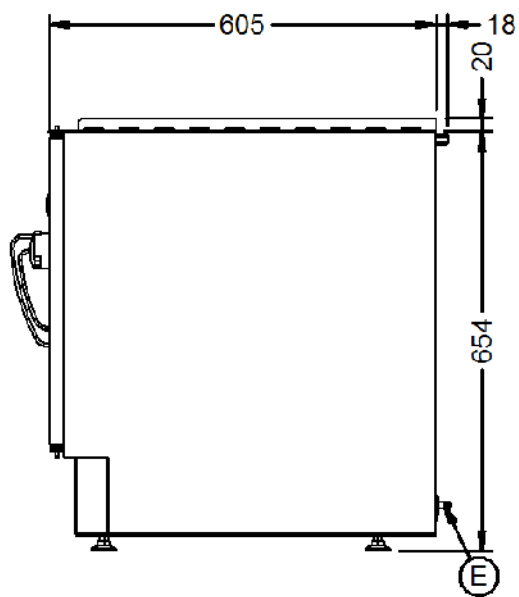
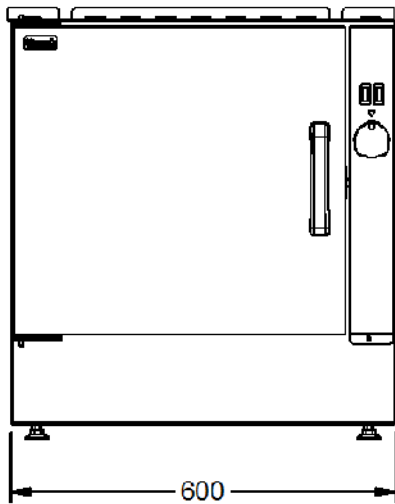
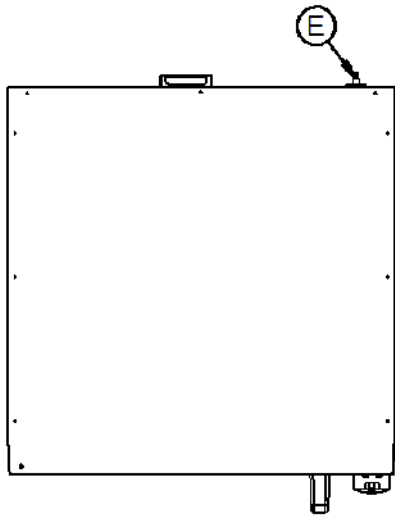

Lincat Limited

Whisby Road,
Lincoln, LN6 3QZ,
United Kingdom

Company No: 2175448

A member company of



Customer Care

Tel: +44 1522 875500
Email: care@lincat.co.uk

Export Customers

Tel: +44 1522 503250
Email: export@lincat.co.uk

Opening Hours

Monday – Friday:
8.30am – 5pm