



TRUE EUROPE

UK OFFICE: Field's End Road, Goldthorpe, Nr. Rotherham, South Yorkshire S63 9EU, UK  
 Tel +44 01709 888 080 • Fax +44 01709 880 838 • Free Phone 0 800 783 2049  
 Free Phone to U.S. 0 800 894 928 • EU OFFICE: Hauptstr. 269 • 79650 Schopfheim • Germany  
 Tel +49 07622 6883 0 • Fax +49 07622 6883 499 • www.truemfg.com



8/16

Model:  
TGU-3-HC

**Gastronorm Undercounter:**  
Solid Door Refrigerator with Hydrocarbon Refrigerant



## TGU-3-HC

- ▶ True undercounter units are designed with enduring quality that protects your long term investment.
- ▶ Designed using the highest quality materials and components to provide the user with colder product temperatures, lower utility costs, exceptional food safety and the best value in today's food service marketplace.
- ▶ Oversized, environmentally friendly (R290) force-air refrigeration system holds .5°C to 3.3°C (33°F to 38°F).
- ▶ Factory engineered, self-contained, capillary tube system using environmentally friendly R290 hydro carbon refrigerant that has zero (0) ozone depletion potential (ODP), & three (3) global warming potential (GWP).
- ▶ Stainless steel exterior front, top and ends. Matching aluminum finished back.
- ▶ Stainless steel interior and door liners.
- ▶ LED temperature display.
- ▶ Front breathing.
- ▶ 3 sets of ¼ gastronorm rails with stainless steel shelves per door section.
- ▶ Foamed-in-place using a high density, polyurethane insulation that has zero ozone depletion potential (ODP) and zero global warming potential (GWP).

ENERGIA - ENERGIJA - ENERGIJA  
 ENERGIJA - ENERGIJA - ENERGIJA  
 ENERGIJA - ENERGIJA - ENERGIJA

2015/1094

### PLAN VIEW

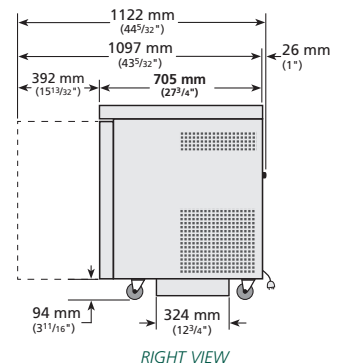
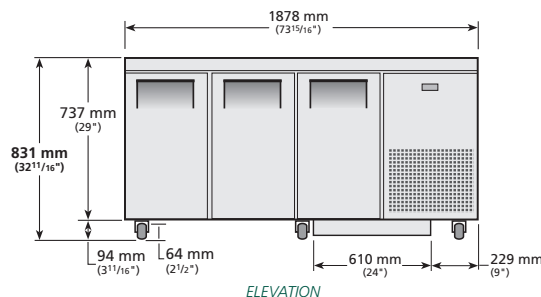

### ROUGH-IN DATA

Specifications subject to change without notice.

Chart dimensions rounded up to the next whole millimeter (inches rounded up to the next 1/8").

Model	Model Type	Doors	Shelves	Cabinet Dimensions (mm)			Net Volume (litres)	EEC	EEI	24 hr/ Energy Consumption (kWh)	Annual Energy Consumption (kWh)	Crated Weight (kg)
				L	D	H						
TGU-3-HC	Counter Chilled	3	9	1880	705	831	285	B	27	1.884	688	209