

PFA SERIES MODELS

FULLY AUTOMATIC VENTLESS COUNTERTOP DEEP FRYER

Advanced by Design



- FULLY AUTOMATED COOKING SYSTEM
- FRONT LOADING/ FRONT DISPENSING
- SMALL FOOTPRINT
- PROGRAMMABLE PRESETS
- ODORLESS
- INTEGRAL VENTLESS HOOD
- INTEGRAL FIRE SUPPRESSION
- LARGEST OUTPUT
- EASY TO CLEAN
- FULLY ENCLOSED
- INTEGRAL INFRARED, CERAMIC HEAT LAMP AND OIL DRAINAGE KIT
- NON-STICK BASKET



PERFECT FRY COMPANY LLC
Mailing Address:
P.O. Box 501
Concord, NH 03302-0501
Shipping Address:
10 Ferry St.
Concord, NH 03301

www.PerfectFry.com

GENERAL INFORMATION:
Phone: 1-603-225-6684
Fax: 1-603-225-8472
Email: profits@perfectfry.com
L10-374 R6

The Benchmark in Ventless Deep Frying



CLEARANCES

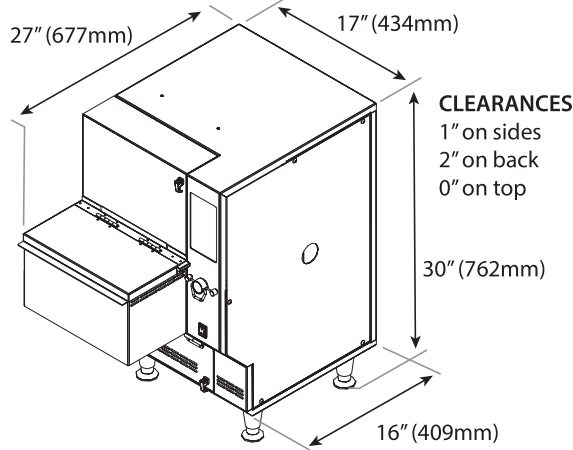

AIRFLOW DIAGRAM

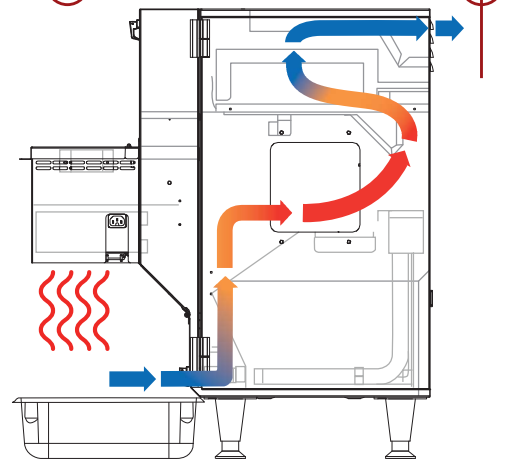

SPECIFICATIONS TABLE

MODEL	PFA720	PFA570	PFA570	PFA375
ORDER NUMBER	Determined by options, please call 1-603-225-6684			
POWER SUPPLY (volts) ¹	240	240	208	240
CURRENT (amps)	32	26	28.5	18
CIRCUIT CURRENT (amps)	min 40*	min 30**	min 30***	min 30**
CORD OPTION	8/3 powercord 6-50 plug	8/3 powercord 6-50 plug	8/3 powercord 6-50 plug	8/3 powercord 6-50 plug
POWER (kilowatts)	7.6	6.1	6	4.2
CAPACITY (lbs/hr)‡	90	70	70	50
HEATER ELEMENT (kilowatts)	7.2	5.7	5.7	3.8

¹other voltages and/or wattages may be available, please contact 1-603-225-6684

ADVANCED ELECTRONIC CAPABILITIES

- Cook Time Sensitivity (CTS)[™]
- Stand-by Mode
- Preset Counters
- Dual Load Cook Cycle
- Food Type Sensitivity (FTS)[™]
- Hold Time Monitor

RAPIDFRY[™] TECHNOLOGY

RapidFry[™] technology allows the operator to pre-load food into the drawer while other food product is frying in the cooking oil. The second load of food will automatically begin cooking once the first cook cycle is completed.

GENERAL SPECIFICATIONS

*For use on an individual branch circuit rated 40A minimum. For supply connectors, use minimum no. 8 AWG wire (40A rated). This fryer must be properly connected to a grounded, dedicated 240 VAC single phase circuit according to local installation standards and codes.

**For use on an individual branch circuit rated 30A minimum. For supply connectors, use minimum no. 10 AWG wire (30A rated). This fryer must be properly connected to a grounded, dedicated 240 VAC single phase circuit according to local installation standards and codes.

***For use on an individual branch circuit rated 30A minimum. For supply connectors, use minimum no. 10 AWG wire (30A rated). This fryer must be properly connected to a grounded, dedicated 208 VAC single phase circuit according to local installation standards and codes.

‡Based on up to 11/2 minute fast fries.

Heat Lamp (see below)	Integral On All Units
Phase	Single (3 wire)
Cycles	50/60 Hz
Weight	125 lbs (57 kg)
Shipping Weight	135 lbs (62 kg)
Shipping Dimensions	Depth 25" (635 mm) Width 22" (559 mm) Height 30" (762 mm)
Shipping Cube	9.52 ft ³ (.271 m ³)
Oil Capacity	2.75 US Gallons (11 L)
Product Capacity	3 lbs per load
****	Locking Cabinet Option also Available

ACCESSORIES

Heat Lamp -
(Part number determined by country,
please call 1-603-225-6684)

2 amps
240 volt
500 watts
Ordered Separately

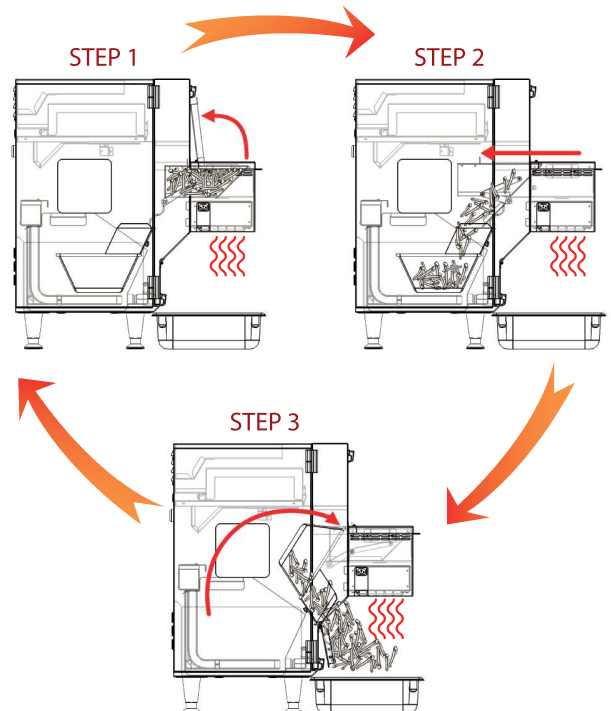

SPECIFICATIONS SUBJECT TO CHANGE WITHOUT NOTICE
© 2013 Perfect Fry Company LLC. Printed in USA
L10-374 R6

