

ORAC2-3 16A Three Phase

(Product Code 710630612)

HIGH SPEED OVEN

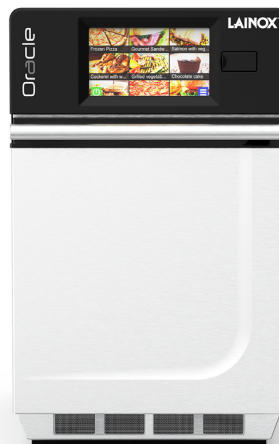

When you need to deliver food fast, you need an oven that does more to help cook delicious food. Everything is faster with ORACLE, from installation to serving customers, to cleaning. With the easy to use touch screen display cooking is simple - just touch the icon of the dish you want and it starts cooking.



IMPINGEMENT

Power up to 3 kW guarantees excellent toasting and browning.



CONVECTION

Temperature from 95°C to 270°C with adjustable fan speed.



MICROWAVE

Power up to 2 kW for rapid heating and reduced cooking times.



CONFIGURABLE DISPLAY

In addition to its highly intuitive 7" touch screen display, ORACLE has a customisable image-based menu which eliminates language and vocabulary barriers.



CONNECTED

Standard WiFi, Ethernet and USB connections.



INSTANTLY CLEAN

Thanks to the standard supply non-stick lining in the oven and rapid cooling system, ORACLE is quickly cleaned at the end of the day.

TECHNICAL DATA

Capacity	lt	17.2	Consumption	A	16
Cooking chamber dimensions	mm	312 x 312 x 178 h	Impingement	kW	3
External dimensions	mm	358 x 743 x 578 h	Microwave	kW	2
Dimensions with packing	mm	600 x 900 x 800 h	Power supply voltage	V	3N-AC 400 V
Weight - Net / Gross	kg	61 / 76	Frequency	Hz	50
Working temperature	°C	95°C / 270°C	Plug configuration		IEC 309
Total electric power	kW	5.95	Cable length	mt	2.4

STANDARD EQUIPMENT

- COOKING PLATE - SMOOTH
- NON-STICK LINING KIT
- WI-FI CONNECTION
- USB CONNECTION
- POWER CABLE AND PLUG

EXTRA ACCESSORIES THAT CAN BE INSTALLED FOLLOWING PURCHASE

- OPC10 - COOKING PLATE - SMOOTH
- OPRG - RIBBED GRILL PLATE - RIFLED
- OCTL280 - SMOOTH TEFLON TRAY - 2 PCS. (280 X 300 X 25 H)
- OCTL140 - SMOOTH TEFLON TRAY - 2 PCS. (140 X 280 X 25 H)
- OCTF300 - PERFORATED TEFLON TRAY - 2 PCS. (300 X 300 X 25 H)
- OCTF150 - PERFORATED TEFLON TRAY - 2 PCS. (150 X 300 X 25 H)
- OPFC - STONE PLATE (280 X 280 X 13 H)
- OPFA - ALUMINIUM PEEL (FOR PUTTING FOOD INTO / TAKING FOOD OUT OF THE OVEN)
- OKRA - NON-STICK LINING KIT - PACK OF 4 KIT
- OSOCL - LIQUID OVEN DETERGENT - CAPACITY 1 L. - PACK OF 6 PCS.
- OSOPR - LIQUID OVEN PROTECTOR - CAPACITY 1 L. - PACK OF 6 PCS.
- OPSA - UPPER SHELF REST
- OPCP - REAR COVER PANEL
- OSR20 - STAINLESS STEEL FLOOR STAND WITH ADJUSTABLE FEET/WHEELS WITH LOW SHELF - ASSEMBLY REQUIRED (700 X 800 X 850 H)
- ORP04 - CASTER KIT FOR FLOOR STANDS, 2 WITH BRAKE
- OKP004 - SET OF FEET FOR OVEN

ORAC2-3

COOKING METHODS

- IMPINGEMENT - 3 KW
- CONVECTION - 95°C / 270°C
- MICROWAVE - 2 KW
- MICROWAVE DEFROST FUNCTION.
- MANUAL UP TO 4 CYCLES.
- PROGRAMMABLE WITH THE ABILITY TO STORE 1200 COOKING PROGRAMMES IN AUTOMATIC SEQUENCE (UP TO 4 CYCLES), ASSIGNING A NAME AND DEDICATED ICON.

OPERATION

- 7" FULLY CUSTOMISABLE TOUCH SCREEN DISPLAY.
- AUTOMATIC PRE-HEATING.

CLEANING AND MAINTENANCE

- APPROVED DETERGENTS CAN BE USED DIRECTLY ON THE SMOOTH DOOR SURFACE.
- REMOVABLE, NON-STICK COOKING CHAMBER LINING FOR EASY CLEANING.
- MAGNETIC AIR FILTERS CAN BE CLEANED IN ONE GO.
- RAPID COOLING FOR FAST CLEANING AT END OF DAY.

CONTROL MECHANISMS

- SILENT FUNCTION: THE FAN SPEED AUTOMATICALLY ADJUSTS BASED ON THE OPERATING MODE.
- REMINDER TO CLEAN AIR FILTERS.
- STANDARD SUPPLY WI-FI/ETHERNET CONNECTION TO UPDATE SOFTWARE AND UPLOAD/DOWNLOAD COOKING PROGRAMMES.
- STANDARD SUPPLY USB CONNECTION TO UPDATE SOFTWARE AND UPLOAD/DOWNLOAD COOKING PROGRAMMES.

CONSTRUCTION

- EXTERNAL STAINLESS STEEL FINISH.
- FRONT CONTROL PANEL IN PAINTED FINISH.
- STAINLESS STEEL OVEN CHAMBER WITH BEVELLED EDGES.
- BUILT-IN CATALYTIC CONVERTER FOR HOOD-FREE USE.
- PULL-DOWN DOOR WITH ERGONOMIC HANDLE.
- IPX3 PROTECTION AGAINST WATER SPLASHES.

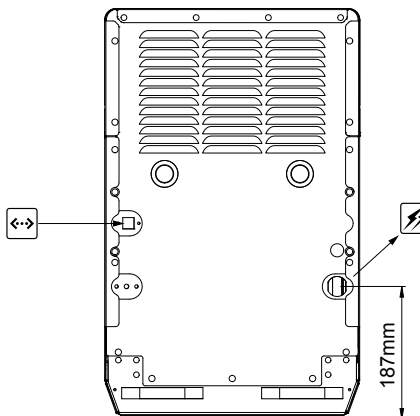
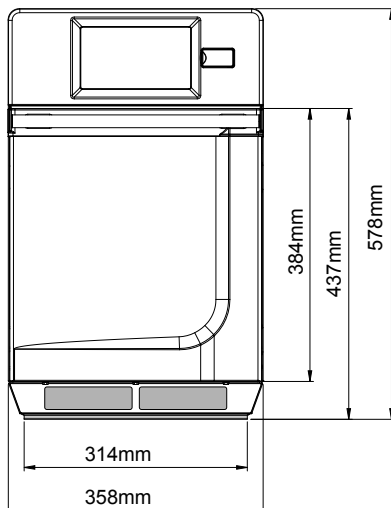
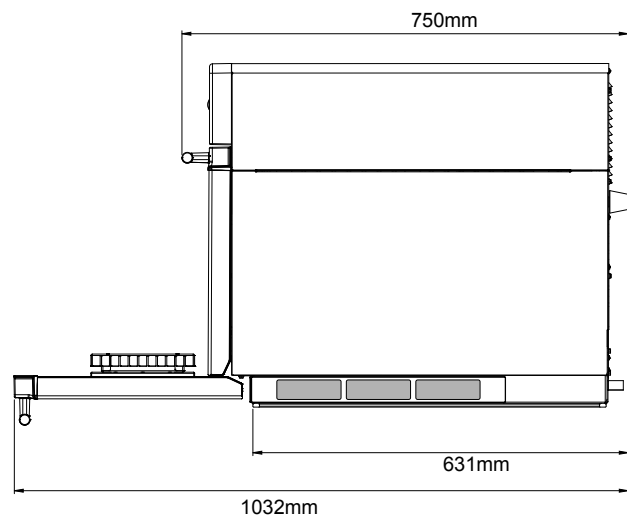
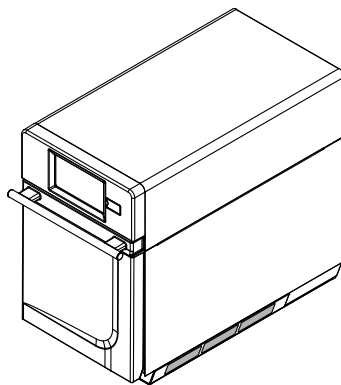

CE IPX3

The data reported in this document is to be considered non-binding. The company reserves the right to make changes at any time, without prior notice.



Falcon Foodservice Equipment, Wallace View, Hillfoots Road, Stirling, FK9 5PY, Scotland, UK

t: +44 (0)1786 455 200 lainox@falconfoodservice.com www.falconfoodservice.com

01.07.2019

LAINOX
DEVICE FOR COOKING