

Technical data sheet for
GAS GRIDDLE 600mm
GP514-B, GP514-CB, GP514-LS

- Heavy-duty thermostatic gas griddle
- 20mm thick griddle plate
- Ribbed plate options
- Mirror chromed plate options
- Top weld sealed plates
- 14.5kW thermostatic burner system
- 2 models of base unit
- Rear rollers
- Stainless steel exterior
- Easy clean
- Easy service
- Fully modular



GP514-LS

Overall Construction

Griddle

- 20mm thick machined top plates standard
- Optional ribbed plate sections
- Optional mirror finish hard chrome plates
- 2.5mm thick 304 stainless steel splash guards sides and rear
- 2.5mm thick grease channel
- 14.5kW single 4 bar even heat burner with single thermostatic control
- Full pilot and flame failure protection with piezo ignition
- Welded hob surround with 1.5mm 304 stainless steel bull nose
- Side panels 1.2mm 304 stainless steel
- Splashback 1.2mm 304 stainless steel
- Enamelled control panel
- Stainless steel grease drawer
- Overlapping finish at front and rear of plate for easy clean

Bench mount (supplied as -B model)

- Four 63mm dia. heavy-duty 1.2mm 304 stainless steel bench legs with adjustable feet.
- Adjustable height 80mm - 105mm

Cabinet base (supplied as -CB model)

- Fully modular for match suite finish
- Double skin 0.9mm 304 stainless steel interior and exterior
- Optional GN 1/1 4 position racking kit
- 63mm dia. heavy-duty 1.2mm 304 stainless steel legs with two adjustable feet at front and two rollers at rear

Leg stand (supplied as -LS model)

- Fully modular for matched suite finish
- Framed top for connection to Griddle
- 63mm dia. heavy-duty 1.2mm 304 stainless steel legs with two adjustable feet at front and two rollers at rear
- Fully modular framed stand shelf with 0.9mm 304 stainless steel finish
- Suitable for rear or through shelf gas connection to Griddle
- Quick assembly design

Controls

- 90-300°C thermostat
- Large easy use control knob - heat resistant reinforced
- Easy view control settings on knob
- Flame failure pilot burner
- Piezo ignition to pilot burner
- Over-temperature safety cut-out

Cleaning and Servicing

- All models with easy clean stainless steel external finish
- Plate is finished front and rear with overlap construction to remove cleaning traps
- Control service and gas conversion through front of unit
- Burner service requires plate removal

Technical data sheet for GAS GRIDDLE 600mm

Specifications

Burner

4 bar chromed steel burner with pilot, flame failure and piezo ignition

Gas power (gross)

14.5kW, 49,300 Btu/hr

Plate

Cooking surface 592mm x 530mm, 3138cm²

Gas connection

R^{3/4} (BSP) male

All units supplied with Natural and LP gas regulator

Dimensions

Bench models

Width 600mm
Depth 812mm
Height 315mm
Incl. splashback 485mm

All models (excluding Bench model)

Width 600mm
Depth 812mm
Height 915mm
Incl. splashback 1085mm

Packing data

Bench and Leg Stand models

0.37m³
Width 645mm
Depth 870mm
Height 665mm

Cabinet Base models

0.70m³
Width 645mm
Depth 870mm
Height 1255mm

Gas types

Available in Natural gas and LP gas, please specify when ordering

Units supplied complete with gas type conversion kits

Options

Adjustable feet at rear
Joining caps
Castors
Ribbed plate options
Mirror chromed plate options

GP514-B

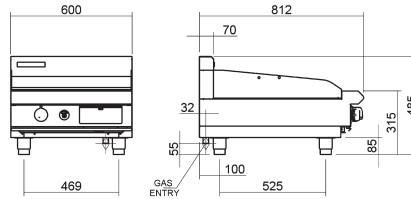

GP514-LS

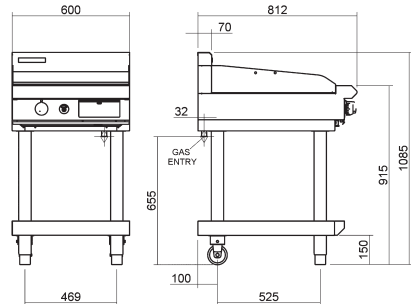

GP514-CB

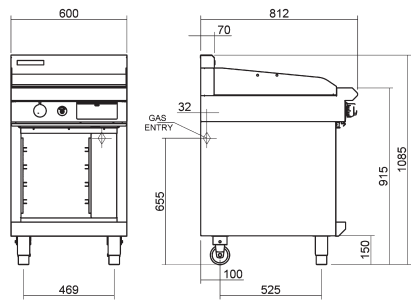

PLAN

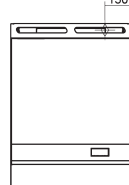

BLUE SEAL

www.blueseal.co.uk
www.bluesealevolution.com

United Kingdom Blue Seal Limited

Unit 67
Gravelly Business Park
Gravelly
Birmingham B24 8TQ
England
Telephone 0121-327 5575
Facsimile 0121-327 9711
Email sales@blue-seal.co.uk
www.blue-seal.co.uk

Australia Moffat Pty Limited

740 Springvale Rd
Mulgrave
Victoria 3170
Australia
Telephone 03-9518 3888
Facsimile 03-9518 3833
Email vsales@moffat.com.au
www.moffat.com.au

New Zealand Moffat Limited

16 Osborne St
PO Box 10-001
Christchurch 8011
New Zealand
Telephone 03-389 1007
Facsimile 03-389 1276
Email sales@moffat.co.nz
www.moffat.co.nz



Designed and manufactured by

MOFFAT

ISO9001
All Blue Seal products are designed and manufactured by Moffat using the internationally recognised ISO9001 quality management system, covering design, manufacture and final inspection, ensuring consistent high quality at all times.

CE

In line with policy to continually develop and improve its products, Moffat Limited reserves the right to change specifications and design without notice.

Printed in China
© Copyright Moffat Ltd
Moffat/4825-UK/BH/2.5M/12.06



BLUE SEAL
EVOLUTIONSERIES