



## DF4/P - Lincat Silverlink 600 Propane Gas Counter-top Single Tank Fryer - 2 Baskets - W 450 mm - 10.5 kW

The Silverlink 600 Gas Single Tank Counter Top Fryer delivers 25kg of chips per hour, while it also features a twin basket operation which gives you the flexibility of cooking different foods or loads simultaneously.

- ✓ Single tank fryer with twin basket operation giving you the flexibility to cook different foods or loads simultaneously, delivering 25kg of chips per hour
- ✓ Piezo ignition for easy lighting
- ✓ Front mounted controls for safety
- ✓ Heavy duty nickel plated baskets for the most demanding of operations
- ✓ Thermostatically controlled to give accurate cooking temperatures throughout cooking. Flame failure device and top temperature cut out ensures safe operation.
- ✓ Front drain off tap for easy removal of cooking oil
- ✓ Cool zone collects cooking debris - gives cleaner cooking results and saves money by prolonging the life of the oil

### Specifications

#### Summary

<b>Brand</b>	Lincat
<b>Range</b>	Silverlink 600
<b>Power Type</b>	Gas
<b>Gas Type</b>	Propane Gas
<b>Unit Type</b>	Counter-top
<b>Available in UK Only</b>	No
<b>UK Warranty</b>	2 Years Parts and Labour Warranty
<b>Export Warranty</b>	Contact your local dealer
<b>GTIN</b>	5056105104612

#### Power and Performance

<b>BTU per Hour</b>	35,826
<b>Total Power kW</b>	10.5
<b>Temperature Range °C</b>	110-190
<b>Temperature Control</b>	Mechanical

#### Key Specifications

<b>Number of Baskets</b>	2
<b>Number of Tanks</b>	1
<b>Gravity Filtration</b>	No
<b>Pumped Filtration</b>	No
<b>Drain Location</b>	Front-mounted

#### Capacity

<b>Product Output per Hour</b>	16kg chips - 12mm [frozen], 25kg chips - 12mm [chi]
<b>Capacity Litres</b>	8.0

#### Weights and Dimensions

<b>Unit Height (External) mm</b>	415
<b>Unit Width (External) mm</b>	450
<b>Unit Depth (External) mm</b>	654
<b>Net Weight Kg</b>	30.9

#### Supply Connections

<b>Requires Installation</b>	Yes
<b>Requires Electrical Supply</b>	No
<b>Gas Connection BSP</b>	1/2"
<b>Gas Consumption at full rate Propane m³ per Hour</b>	0.75
<b>Gas Pressure Propane mbar</b>	35.0
<b>Total heat input at full rate Propane kW</b>	10.5
<b>Total heat input at full rate Propane BTU per hour</b>	38,600

## Shipping

Packed Weight Kg	43.2
Packed Height cm	63.5
Packed Width cm	70
Packed Depth cm	55

## Available Accessories

<b>CH01</b>	Caterflex Hose 1/2" - 1 Metre - for use with units up to 66,000 BTU
<b>CH02</b>	Caterflex Hose 1/2" - 1.5 Metre - for use with units up to 56,000 BTU
<b>CN4</b>	Lincat Silverlink 600 Free-standing Ambient Open-Top Pedestal without Doors - W 450 mm
<b>DC01</b>	DONUT CONV KIT DF4/GAS
<b>SLS4</b>	Lincat Silverlink 600 Free-standing Floor Stand - for units W 450 mm

## Technical Picture

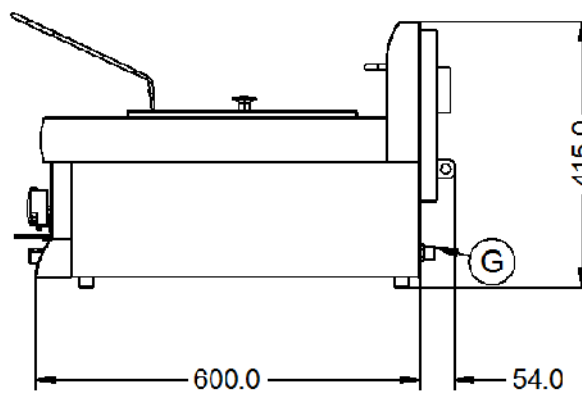
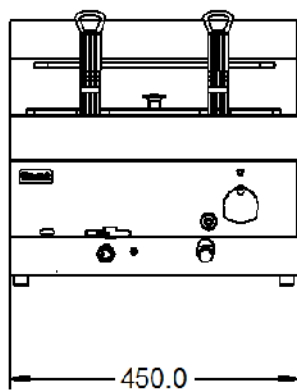
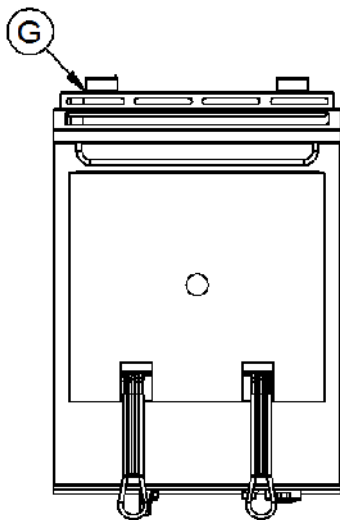



#### Lincat Limited

Whisby Road,  
Lincoln, LN6 3QZ,  
United Kingdom

**Company No:** 2175448

A member company of



#### Customer Care

**Tel:** +44 1522 875500  
**Email:** [care@lincat.co.uk](mailto:care@lincat.co.uk)

#### Export Customers

**Tel:** +44 1522 503250  
**Email:** [export@lincat.co.uk](mailto:export@lincat.co.uk)

#### Opening Hours

**Monday – Friday:**  
8.30am – 5pm